

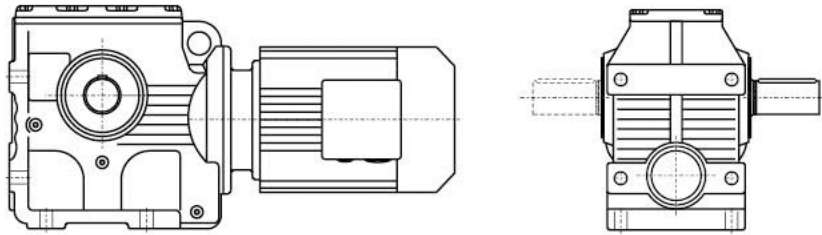

S系列减速机有以下设计方案：
S series gear units are available in the following designs:

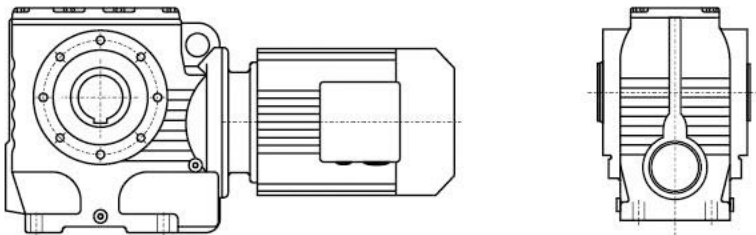

S..Y..
底脚轴伸式安装斜齿-蜗轮蜗杆减速机
Foot-mounted helical-worm gear units with solid shaft



SA...Y...
空心轴安装斜齿-蜗轮蜗杆减速机
Helical-worm gear units with hollow shaft

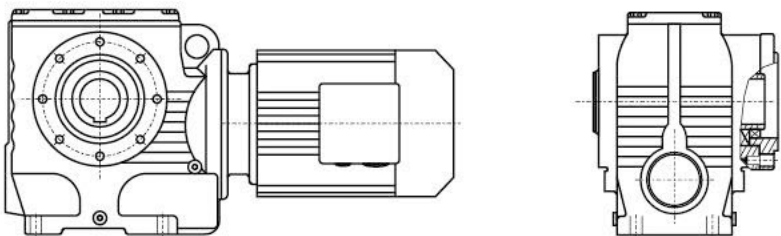

SAZ...Y...
小法兰空心轴安装斜齿-蜗轮蜗杆减速机
Short-flange mounted helical-worm gear units with hollow shaft

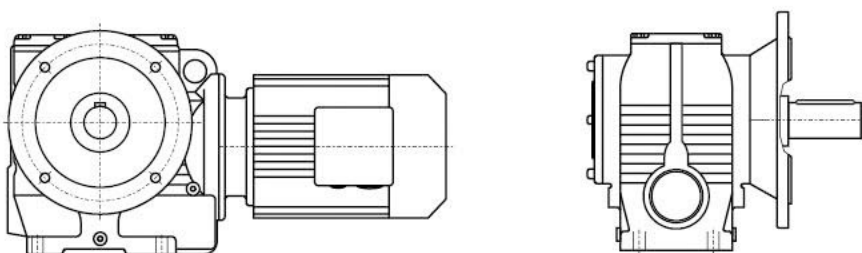

SF...Y..
法兰轴伸式安装斜齿-蜗轮蜗杆减速机
Flange-mounted helical-worm gear units with solid shaft

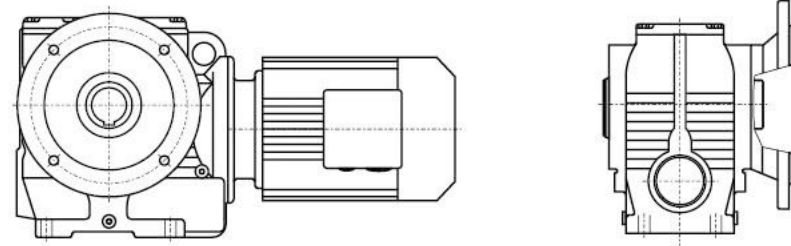

SAF...Y..
法兰空心轴安装斜齿-蜗轮蜗杆减速机
Flange-mounted helical-worm gear units with hollow shaft

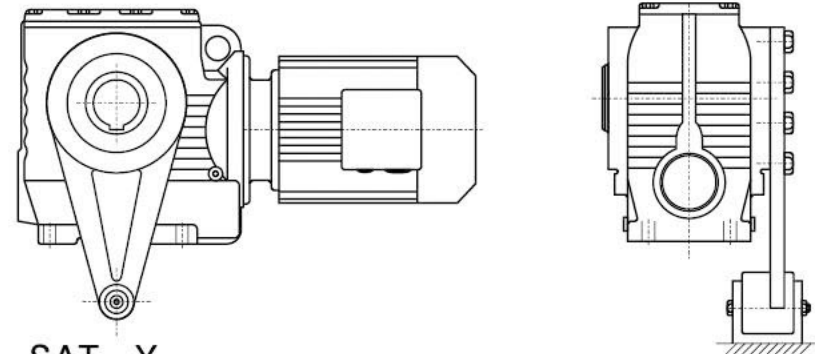

SAT...Y..
带防转臂空心轴安装斜齿-蜗轮蜗杆减速机
Torque-arm-mounted helical-worm gear units with hollow shaft

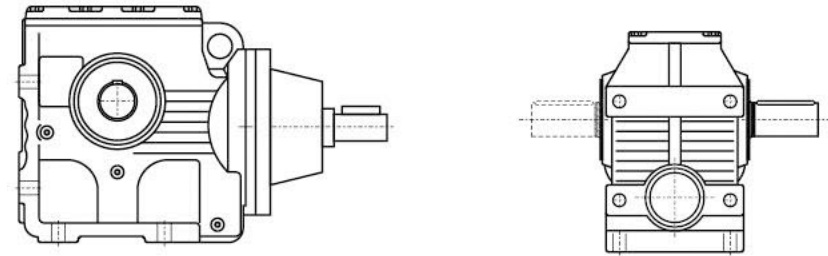

S(SF, SA, SAF, SAZ) S...
轴输入的斜齿-蜗轮蜗杆减速机
Shaft input helical-worm gear units

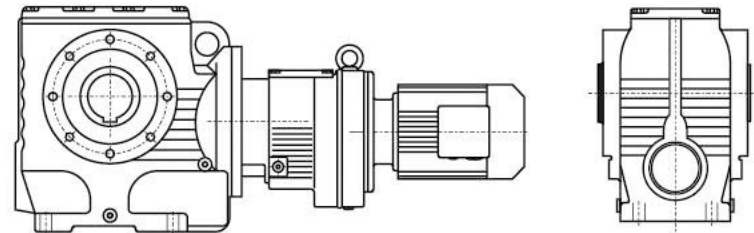

SA(S, SF, SAF, SAZ) ...R...Y...
组合式斜齿-蜗轮蜗杆减速机
Combinatorial helical-worm gear units

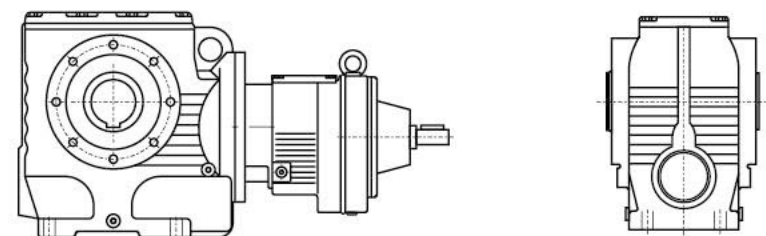

SA(S, SF, SAF, SAZ) S...R...
轴输入的组合式斜齿-蜗轮蜗杆减速机
Shaft input combinatorial helical-worm gear units

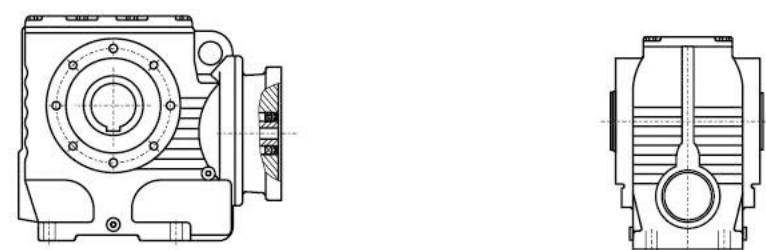

SA(S, SF, SAF, SAZ) ...Y...
电机用户自配或配特殊电机时需加联接法兰
When equipping the user's motor or the special one, the flange is required to be connected



型号与标记:
Type Designations:

SAF37-Y 0.55-4P-12.08-M1-270°-A-Φ25	SAF37-Y 0.55-4P-12.08-M1-270°-A-Φ25
<p>减速机类型 结构形式 规格 电机代号 电机功率、极数 传动比 安装形式 电机接线盒位置 输出轴、锁紧盘或法兰方向 输出轴孔径</p>	<p>Gear units type Structure Size Motor code Motor power, pole Ratio Mounting position Position of the motor thermal box Position of output shaft, shrink disk or flange Output shaft aperture</p>
<p>减速机类型: 斜齿-蜗轮蜗杆减速机</p>	<p>Gear units type: Helical-worm gear units</p>
<p>结构形式: 普通轴伸式 (省略) 轴装式 A 轴伸法兰式 F 轴装法兰式 AF 轴装小法兰式 AZ 轴装带防转臂 AT 普通轴伸式, 轴输入 S 普通轴装式, 轴输入 AS 轴伸法兰式, 轴输入 FS 轴装法兰式, 轴输入 AFS *带锁紧盘式 H..(H,HF,HZ,HT)</p>	<p>Structure: Foot-mounted solid shaft output (-) Hollow shaft output A Flange-mounted solid shaft output F Flange-mounted hollow shaft output AF Short-flange-mounted hollow shaft output AZ Torque-arm-mounted hollow shaft output AT Foot-mounted solid shaft output, shaft input S Hollow shaft output, shaft input AS Flange-mounted solid shaft output, shaft input FS Flange-mounted hollow shaft output, shaft input AFS *Hollow shaft output with shrink disk H..(H,HF,HZ,HT)</p>
<p>规格: (见选型参数表)</p>	<p>Size: (see selection table)</p>
<p>电机代号: 普通(更新) Y(Y2) 防爆 B 直流 Z 制动 YEJ 多速 D 变频 YVP 电磁调速 YCT 冶金起重 R 变频制动 YVPJ 辊道 G</p>	<p>Motor code: Ordinary(renew) Y(Y2) Flame-proof B Direct current Z Brake YEJ Multi-speed D Variable frequency YVP Electromagnetism speed modulation YCT Hoisting in metallurgy R Variable frequency and brake YVPJ Roller tables G</p>
<p>电机功率、极数: (见选型参数表)</p>	<p>Motor power, pole : (see selection table)</p>
<p>传动比: (见选型参数表)</p>	<p>Ratio: (see selection table)</p>
<p>安装形式: M1、M2、M3、M4、M5、M6 (见第72页)</p>	<p>Mounting position: M1、M2、M3、M4、M5、M6(see page 72)</p>
<p>电机接线盒位置: 0°、90°、180°、270° (见第72页)</p>	<p>Position of the motor thermal box: 0°、90°、180°、270° (see page 72)</p>
<p>输出轴、锁紧盘或法兰方向: 从电机尾部看左边为 A 从电机尾部看右边为 B (见安装形式) 从电机尾部看左右边为 A+B</p>	<p>Position of output shaft or flange: viewing on motor end:left side -A, right side-B,both sides-A+B(see mounting position)</p>
<p>输出轴孔径: (见安装尺寸图)带实心轴输出时省略</p>	<p>Output shaft aperture: (see the chart of mouting dimension) It will be omitted when solid output shaft</p>

*带锁紧盘式, 详见454-455页。

*Hollow shaft output with shrink disk, see P454-455 for detail.





安装形式
Mounting position

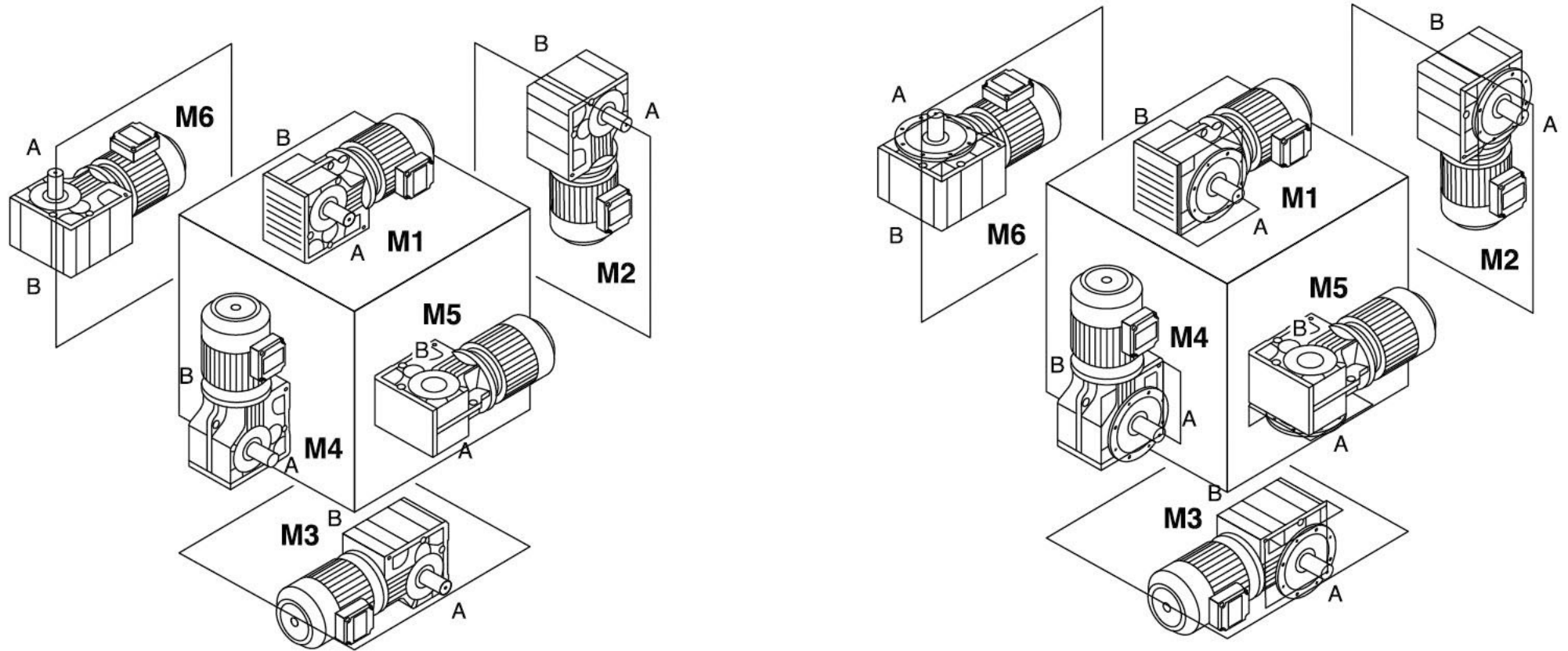

S

电机接线盒位置
Position of the motor thermal box

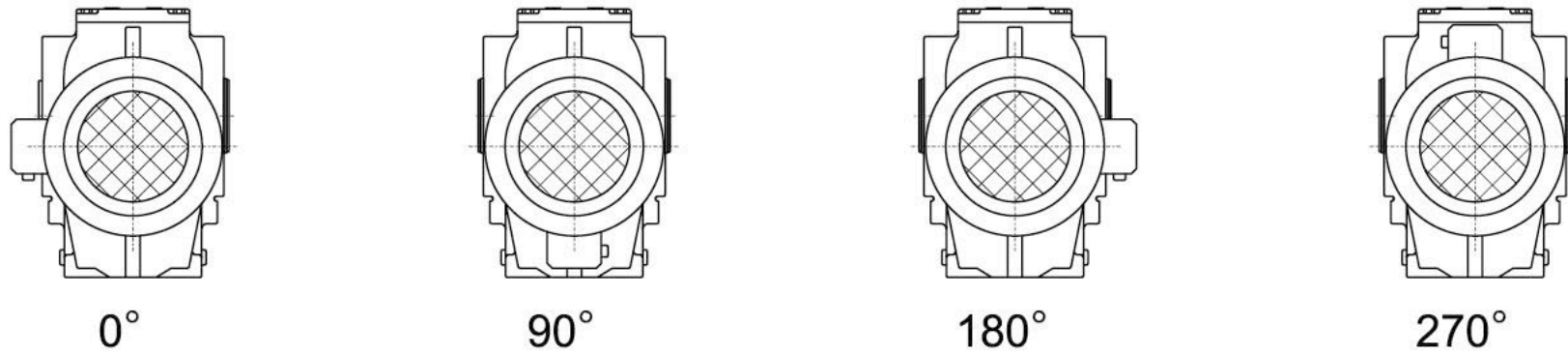

输入功率及许用转矩
Input power rating and permissible torque

规格 Size	37	47	57	67	77	87	97
结构形式 Structure	S SA SF SAF SAT SAZ						
输入功率(kW) Input power rating	0.18~0.75	0.18~1.5	0.18~3	0.25~5.5	0.55~7.5	0.75~15	1.5~22
传动比 Ratio	10.27~165.71	11.46~244.74	10.78~196.21	11.55~227.20	9.96~241.09	11.83~223.26	12.75~230.48
许用转矩(N.m) Permissible torque	90	170	300	520	1270	2280	4000



减速机重量
Gear unit weight

规格 Size	37	47	57	67	77	87	97
重量(kg) Weight	7	10	14	26	50	100	170

所注重量为平均值, 仅供参考

The weights are mean values, only for reference.

润滑油量表
Lubrication table

S...:

规格 Size	润滑油量 (升)			Fill quantity in liters		
	M1	M2	M3 ¹⁾	M4	M5	M6
S37	0.25	0.4	0.5	0.6	0.4	0.4
S47	0.35	0.8	0.7	1.1	0.8	0.8
S57	0.5	1.2	1	1.5	1.3	1.3
S67	1	2.0	2.2/3.1	3.2	2.6	2.6
S77	1.9	4.2	3.7/5.4	6	4.4	4.4
S87	3.3	8.1	6.9/10.4	12	8.4	8.4
S97	6.8	15	13.4/18	22.5	17	17

S

SF...:

规格 Size	润滑油量 (升)			Fill quantity in liters		
	M1	M2	M3 ¹⁾	M4	M5	M6
SF37	0.25	0.4	0.5	0.6	0.4	0.4
SF47	0.4	0.9	0.9	1.2	1.0	1.0
SF57	0.5	1.2	1	1.6	1.4	1.4
SF67	1	2.2	2.3/3	3.2	2.7	2.7
SF77	1.9	4.1	3.9/5.8	6.5	4.9	4.9
SF87	3.8	8	7.1/10.1	12	9.1	9.1
SF97	7.4	15	13.8/18.8	23.6	18	18

SA...、SAF...、SAZ...:

规格 Size	润滑油量 (升)			Fill quantity in liters		
	M1	M2	M3 ¹⁾	M4	M5	M6
S..37	0.25	0.4	0.5	0.6	0.4	0.4
S..47	0.4	0.8	0.7	1.1	0.8	0.8
S..57	0.5	1.1	1	1.6	1.2	1.2
S..67	1	2.0	1.8/2.6	2.9	2.5	2.5
S..77	1.8	3.9	3.6/5	5.9	4.5	4.5
S..87	3.8	7.4	6/8.7	11.2	8	8
S..97	7	14	11.4/16	21	15.7	15.7

注: 1) 表示减速机为组合型时低速级所加油量为大值。

Notes: 1) The large gear unit of multi-stage gear units must be filled with the larger oil volume.



输出转速 Output speed r/min	输出扭矩 Output torque Nm	传动比 Ratio i	使用系数 Service factor f _B	机型号 Type Type	极数 Pole p	输出转速 Output speed r/min	输出扭矩 Output torque Nm	传动比 Ratio i	使用系数 Service factor f _B	机型号 Type Type	极数 Pole p
0.25kW						0.37kW					
3.7	383	227.20	1.28			0.68	2611	2054	0.82	S 87R57	4
4.1	346	205.11	1.41	S 67	6	0.76	2488	1824	0.86	SF 87R57	4
4.7	304	180.46	1.61	SF 67	6	0.85	2318	1631	0.92	SA 87R57	4
5.0	287	170.40	1.70	SA 67	6	1.5	1655	930	1.29	SAF87R57	4
5.9	243	144.00	2.01	SAF67	6	1.7	1479	831	1.45		
6.1	234	227.20	2.09			1.9	1271	714	0.94		
6.8	211	205.11	2.31			2.2	1134	637	1.05	S 77R37	4
7.7	186	180.46	2.63	S 67	4	2.4	1021	574	1.17	SF 77R37	4
8.2	176	170.40	2.78	SF 67	4	2.8	888	499	1.34	SA 77R37	4
9.7	148	144.00	3.30	SA 67	4	3.2	779	438	1.53	SAF77R37	4
11	134	130.00	3.65	SAF67	4	3.6	692	389	1.72		
12	118	114.38	4.15			3.8	557	365	0.88	S 67R37	4
13	111	108.00	4.39			4.4	568	319	0.92	SF 67R37	4
4.3	331	196.21	0.85	S 57	6	4.9	500	281	0.98	SA 67R37	4
4.7	304	180.40	0.93	SF 57	6	5.7	438	246	1.12	SAF67R37	4
5.5	260	154.35	1.08	SA 57	6	3.0	702	222.00	3.03	S 87	8
6.4	225	133.79	1.25	SAF57	6	3.4	627	198.00	3.42	SF 87	8
6.8	211	125.05	1.34			4.0	527	166.43	3.71	SA 87	8
7.1	202	196.21	1.39							SAF87	8
7.7	186	180.40	1.52			2.8	763	241.09	1.57	S 77	8
9.0	159	154.35	1.77	S 57	4	3.3	652	206.04	1.83	SF 77	8
10	138	133.79	2.05	SF 57	4	3.5	598	188.89	2.00	SA 77	8
11	129	125.05	2.19	SA 57	4	4.0	524	165.75	2.28	SAF77	8
13	111	108.09	2.53	SAF57	4	4.3	497	157.08	2.40		
15	95	91.84	2.98			3.9	544	227.20	0.90	S 67	6
17	85	82.00	3.34			4.3	491	205.11	1.00	SF 67	6
7.0	204	197.73	0.81			4.9	432	180.46	1.13	SA 67	6
8.3	173	168.00	0.92			5.2	408	170.40	1.20	SAF67	6
9.3	155	150.00	1.04			6.1	345	144.00	1.42		
9.5	151	146.84	1.06			6.1	347	227.20	1.41		
10	141	137.25	1.13			6.8	313	205.11	1.56	S 67	4
12	122	118.64	1.31	S 47	4	7.7	275	180.46	1.78	SF 67	4
14	104	100.80	1.54	SF 47	4	8.2	260	170.40	1.88	SA 67	4
15	93	90.00	1.58	SA 47	4	9.7	220	144.00	2.23	SAF67	4
18	79	76.88	2.02	SAF47	4	11	198	130.00	2.47		
19	74	72.00	1.98			12	174	114.38	2.80		
23	71	60.65	2.24			5.7	370	154.35	0.81		
24	63	59.32	2.07			6.6	321	133.79	0.88	S 57	6
28	61	50.40	2.41			7.1	300	125.05	0.94	SF 57	6
31	54	45.00	2.72			8.2	259	108.09	1.09	SA 57	6
13	107	104.00	0.81			9.6	220	91.84	1.28	SAF57	6
15	94	90.91	0.91			10.8	196	82.00	1.44		
16	88	85.22	0.97			7.1	299	196.21	0.94		
18	77	75.20	1.10			7.7	275	180.40	1.02		
21	69	66.67	1.24			9.0	235	154.35	1.20		
25	63	56.67	1.36			10	204	133.79	1.38	S 57	4
27	58	52.00	1.22			11	191	125.05	1.48	SF 57	4
31	55	45.45	1.39			13	165	108.09	1.71	SA 57	4
33	51	42.61	1.47			15	140	91.84	2.01	SAF57	4
37	45	37.60	1.64	S 37	4	17	125	82.00	2.25		
42	40	33.33	1.8	SF 37	4	20	119	70.04	2.64		
49	34	28.33	2.09	SA 37	4	21	111	66.89	1.95		
59	32	23.46	2.16	SAF37	4	22	107	62.53	2.09		
74	26	18.85	2.59			10	209	137.25	0.80	S 47	4
84	23	16.48	2.14			12	181	118.64	0.88	SF 47	4
90	21	15.45	2.26			14	154	100.80	1.04	SA 47	4
102	19	13.63	2.45			15	137	90.00	1.17	SAF47	4
115	17	12.08	2.68			18	117	76.88	1.36		
135	14	10.27	3.25								





输出转速 Output speed r/min	输出扭矩 Output torque Nm	传动比 Ratio i	使用系数 Service factor f _B	机型号 Type Type	极数 Pole p	输出转速 Output speed r/min	输出扭矩 Output torque Nm	传动比 Ratio i	使用系数 Service factor f _B	机型号 Type Type	极数 Pole p
0.37kW						0.55kW					
19	110	72.00	1.46			3.7	859	241.09	1.39		
23	106	60.65	1.52			4.3	734	206.04	1.63	S 77	6
24	93	59.32	1.38			4.7	673	188.89	1.78	SF 77	6
28	90	50.40	1.63			5.3	590	165.75	2.02	SA 77	6
31	80	45.00	1.84	S 47	4	5.6	559	157.08	2.13	SAF77	6
36	68	38.44	2.16	SF 47	4						
39	64	36.00	2.30	SA 47	4	5.8	547	241.09	2.18	S 77	4
46	54	30.33	2.72	SAF47	4	6.7	467	206.04	2.56	SF 77	4
50	56	27.74	2.57			7.4	428	188.89	2.79	SA 77	4
54	53	25.93	1.97							SAF77	4
62	46	22.41	2.97			6.1	515	227.20	0.95		
73	39	19.04	2.67			6.8	465	205.11	1.05		
82	35	17.00	2.98			7.7	409	180.46	1.20		
						8.2	386	170.40	1.27		
21	102	66.67	0.84			9.7	326	144.00	1.50		
25	93	56.67	0.92			11	295	130.00	1.66	S 67	4
27	86	52.00	0.82			12	259	114.38	1.89	SF 67	4
31	81	45.45	0.95			13	245	108.00	2.00	SA 67	4
33	76	42.61	0.98			15	208	91.96	2.35	SAF67	4
37	67	37.60	1.10	S 37	4	17	189	83.57	2.58		
42	59	33.33	1.22	SF 37	4	19	172	72.39	2.78		
49	50	28.33	1.42	SA 37	4	21	164	65.00	2.84		
59	48	23.46	1.44	SAF37	4						
74	38	18.85	1.77			9.6	327	91.84	0.86		
84	34	16.48	1.45			11	292	82.00	0.97		
90	31	15.45	1.53			12	251	70.40	1.01	S 57	6
102	28	13.63	1.66			13	278	66.89	0.83	SF 57	6
115	25	12.08	1.82			14	260	62.53	0.89	SA 57	6
135	21	10.27	2.17			16	225	54.05	1.11	SAF57	6
						19	191	45.92	1.21		
						22	170	41.00	1.36		
						25	146	35.20	1.60		
0.55kW						0.55kW					
1.0	2517	1332	0.85			9.0	350	154.35	0.81		
1.2	2475	1191	0.87			10	303	133.79	0.93		
1.3	2460	1032	0.87			11	284	125.05	0.99		
1.5	2340	930	0.92	S 87R57	4	13	245	108.09	1.15		
1.7	2198	831	0.97	SF 87R57	4	15	208	91.84	1.35		
1.9	1902	719	1.13	SA 87R57	4	17	186	82.00	1.52		
2.2	1651	624	1.30	SAF87R57	4	20	177	70.40	1.59		
2.5	1476	558	1.45			21	165	66.89	1.31	S 57	4
3.2	1151	435	1.86			22	160	62.53	1.41	SF 57	4
						26	143	54.05	1.76	SA 57	4
2.8	1320	499	0.90			30	121	45.92	1.92	SAF57	4
3.2	1159	438	1.03	S 77R37	4	34	108	41.00	2.15		
3.6	1029	389	1.16	SF 77R37	4	40	93	35.02	2.50		
4.3	865	327	1.38	SA 77R37	4	42	91	32.80	2.67		
4.8	764	289	1.56	SAF77R37	4	46	87	30.12	2.55		
5.6	661	250	1.81			53	79	26.11	2.94		
						57	74	24.40	3.14		
5.7	558	246	0.84	S 67R37	4	66	64	21.09	3.63		
6.3	585	221	0.88	SF 67R37	4						
7.0	524	198	0.93	SA 67R37	4	18	174	76.88	0.92		
8.3	444	168	1.10	SAF67R37	4	19	163	72.00	0.98		
						23	157	60.65	1.02		
3.0	1044	222.00	2.05	S 87	8	25	138	59.32	0.93		
3.4	931	198.00	2.14	SF 87	8	28	133	50.40	1.10		
4.0	783	166.43	2.49	SA 87	8	31	119	45.00	1.23		
				SAF87	8	36	102	38.44	1.44	S 47	4
						39	95	36.00	1.55	SF 47	4
4.0	791	222.00	2.71	S 87	6	46	80	30.33	1.84	SA 47	4
4.5	705	198.00	2.82	SF 87	6	50	84	27.74	1.71	SAF47	4
5.3	593	166.43	3.30	SA 87	6	54	78	25.93	1.33		
				SAF87	6	62	68	22.41	2.01		
						73	58	19.04	1.80		
3.3	969	206.04	1.23	S 77	8	82	51	17.00	2.04		
3.5	888	188.89	1.34	SF 77	8	96	44	14.52	2.37		
4.0	780	165.75	1.53	SA 77	8	102	41	13.60	2.52		
4.3	739	157.08	1.62	SAF77	8	121	35	11.46	2.94		



输出转速 Output speed r/min	输出扭矩 Output torque Nm	传动比 Ratio i	使用系数 Service factor f _B	机型号 Type Type	极数 Pole p	输出转速 Output speed r/min	输出扭矩 Output torque Nm	传动比 Ratio i	使用系数 Service factor f _B	机型号 Type Type	极数 Pole p
0.55kW						0.75kW					
42	88	33.33	0.82			6.8	634	205.11	0.80		
49	75	28.33	0.95			7.7	558	180.46	0.88		
59	71	23.46	0.97			8.2	527	170.40	0.93		
74	57	18.85	1.18	S 37	4	9.7	445	144.00	1.10		
84	50	16.48	0.98	SF 37	4	11	402	130.00	1.22		
90	47	15.45	1.01	SA 37	4	12	354	114.38	1.38	S 67	4
102	41	13.63	1.13	SAF37	4	13	334	108.00	1.46	SF 67	4
115	37	12.08	1.23			15	284	91.96	1.72	SA 67	4
135	31	10.27	1.47			17	258	83.57	1.89	SAF67	4
0.75kW						0.75kW					
1.1	4411	1223	0.85			19	224	72.39	2.09		
1.3	3860	1070	0.97			21	234	65.00	2.18		
1.5	3347	928	1.12	S 97R57	4	22	206	63.00	2.37		
1.7	2972	824	1.27	SF 97R57	4	24	195	57.19	2.21		
1.9	2575	714	1.46	SA 97R57	4	26	185	54.00	2.51		
2.2	2258	626	1.67	SAF97R57	4	30	166	45.98	2.70		
2.6	1941	538	1.94			13	331	70.04	0.80		
2.9	1746	484	2.2			14	369	66.89	0.82	S 57	6
1.3	2659	1032	0.81			15	345	62.53	0.85	SF 57	6
1.5	2593	930	0.83			17	298	54.05	0.84	SA 57	6
1.7	2569	831	0.83	S 87R57	4	20	253	45.92	0.91	SAF57	6
1.9	2396	719	0.89	SF 87R57	4	22	226	41.00	1.02		
2.2	2251	624	0.95	SA 87R57	4	13	334	108.09	0.84		
2.5	2013	558	1.06	SAF87R57	4	15	284	91.84	0.99		
3.2	1569	435	1.37			17	254	82.00	1.11		
4.3	1165	323	1.84			20	217	70.04	1.17		
4.3	1179	327	1.01	S 77R37	4	21	241	66.89	0.96		
4.8	1042	289	1.15	SF 77R37	4	22	226	62.53	1.02		
5.6	902	250	1.32	SA 77R37	4	26	195	54.05	1.29	S 57	4
6.3	790	219	1.51	SAF77R37	4	30	166	45.92	1.40	SF 57	4
3.0	1457	230.48	2.58	S 97	8	34	148	41.00	1.57	SA 57	4
3.3	1311	207.48	2.87	SF 97	8	40	126	35.02	1.84	SAF57	4
3.6	1187	187.89	3.17	SA 97	8	42	118	32.80	1.97		
				SAF97	8	46	124	30.12	1.87		
4.1	1048	222.00	2.04	S 87	6	53	108	26.11	2.15		
4.6	935	198.00	2.13	SF 87	6	57	101	24.40	2.30		
5.5	786	166.43	2.48	SA 87	6	66	87	21.09	2.67		
				SAF87	6	78	74	17.92	2.15		
6.2	690	223.26	1.95	S 87	4	87	66	16.00	3.09		
7.0	612	198.00	2.10	SF 87	4	102	56	13.67	2.85		
8.4	515	166.43	2.50	SA 87	4	31	162	45.00	0.99		
				SAF87	4	36	139	38.44	1.15		
3.8	1139	241.09	1.05	S 77	6	39	130	36.00	1.23		
4.4	973	206.04	1.23	SF 77	6	46	109	30.33	1.40	S 47	4
4.8	892	188.89	1.34	SA 77	6	50	114	27.74	1.26	SF 47	4
5.5	783	165.75	1.53	SAF77	6	54	107	25.93	0.97	SA 47	4
						62	92	22.41	1.48	SAF47	4
5.8	745	241.09	1.60			73	78	19.04	1.33		
6.7	637	206.04	1.87			82	70	17.00	1.49		
7.4	584	188.89	2.04	S 77	4	96	60	14.52	1.74		
8.4	512	165.75	2.33	SF 77	4	102	56	13.60	1.84		
8.8	486	157.08	2.46	SA 77	4	121	47	11.46	2.20		
10	425	137.48	2.81	SAF77	4	74	78	18.85	0.86		
11	383	123.86	3.12			84	68	16.48	0.85	S 37	4
13	336	108.65	3.55			90	64	15.45	0.84	SF 37	4
						102	56	13.63	0.83	SA 37	4
						115	50	12.08	0.91	SAF37	4
						135	42	10.27	1.08		

S



输出转速 Output speed r/min	输出扭矩 Output torque Nm	传动比 Ratio i	使用系数 Service factor f _B	机型号 Type Type	极数 Pole p	输出转速 Output speed r/min	输出扭矩 Output torque Nm	传动比 Ratio i	使用系数 Service factor f _B	机型号 Type Type	极数 Pole p
1.1kW						1.1kW					
1.7	4328	824	0.87			20	351	70.04	0.80		
2.0	3750	714	1.00	S 97R57	4	21	328	66.89	0.86		
2.2	3288	626	1.14	SF 97R57	4	22	315	62.53	0.89		
2.6	2826	538	1.33	SA 97R57	4	26	284	54.05	0.88		
2.9	2542	484	1.48	SAF97R57	4	30	241	45.92	0.96		
3.3	2206	420	1.70			34	215	41.00	1.07		
						40	184	35.02	1.25	S 57	4
2.2	2547	624	0.84			43	181	32.80	1.35	SF 57	4
2.5	2512	558	0.85			46	172	30.12	1.42	SA 57	4
2.9	2341	485	0.92			54	157	26.11	1.48	SAF57	4
3.2	2285	435	0.94	S 87R57	4	57	146	24.40	1.59		
3.7	1985	378	1.08	SF 87R57	4	66	127	21.09	1.83		
4.3	1697	323	1.26	SA 87R57	4	78	108	17.92	1.46		
5.0	1476	281	1.45	SAF87R57	4	88	96	16.00	2.11		
5.5	1339	255	1.35			102	82	13.67	1.94		
6.3	1166	222	1.55			109	77	12.80	2.06		
6.8	1077	205	1.65			130	65	10.78	2.45		
6.4	1150	219	1.04	S 77R37	4	46	182	30.33	0.88		
				SF 77R37	4	50	167	27.74	0.96		
				SA 77R37	4	54	156	25.93	0.99	S 47	4
				SAF77R37	4	62	135	22.41	1.01	SF 47	4
						74	114	19.04	0.91	SA 47	4
3.0	2136	230.48	1.76	S 97	8	82	102	17.00	1.02	SAF47	4
3.3	1923	207.48	1.96	SF 97	8	96	87	14.52	1.20		
3.6	1742	187.89	2.16	SA 97	8	103	82	13.60	1.25		
				SAF97	8	122	69	11.46	1.50		
3.9	1596	230.48	2.36	S 97	6	1.5kW					
4.4	1437	207.48	2.62	SF 97	6	2.0	4484	714	0.84		
4.8	1301	187.89	2.89	SA 97	6	2.2	4383	626	0.86	S 97R57	4
				SAF97	6	2.6	3853	538	0.98	SF 97R57	4
						2.9	3467	484	1.08	SA 97R57	4
6.3	999	222.00	1.85	S 87	4	3.3	3008	420	1.25	SAF97R57	4
7.1	891	198.00	2.20	SF 87	4	3.7	2693	376	1.40		
8.4	749	166.43	2.60	SA 87	4	4.3	2342	327	1.61		
9.2	689	152.95	2.74	SAF87	4						
10.3	612	135.83	3.02			2.9	2707	485	0.79		
						3.2	2481	435	0.86		
5.8	1085	241.09	1.10			3.7	2313	378	0.93	S 87R57	4
6.8	928	206.04	1.29			4.3	2225	323	0.96	SF 87R57	4
7.4	850	188.89	1.40	S 77	4	5.0	2013	281	1.06	SA 87R57	4
8.4	746	165.75	1.60	SF 77	4	5.5	1826	255	1.01	SAF87R57	4
8.9	707	157.08	1.69	SA 77	4	6.3	1590	222	1.10		
10	619	137.48	1.93	SAF77	4	6.8	1468	205	1.20		
11	558	123.86	2.05								
13	489	108.65	2.32			3.0	2871	230.48	1.31	S 97	8
15	432	95.88	2.56			3.3	2584	207.48	1.45	SF 97	8
						3.7	2340	187.89	1.61	SA 97	8
11	585	130.00	0.84			4.1	2076	166.62	1.81	SAF97	8
12	515	114.38	0.95								
13	486	108.00	1.01			4.0	2153	230.48	1.75	S 97	6
15	414	91.96	1.18			4.4	1938	207.48	1.94	SF 97	6
17	376	83.57	1.30			4.9	1755	187.89	2.14	SA 97	6
19	341	72.39	1.43	S 67	4	5.5	1557	166.62	2.42	SAF97	6
22	326	65.00	1.50	SF 67	4						
23	284	63.00	1.60	SA 67	4	6.1	1415	230.48	2.66	S 97	4
24	300	57.19	1.51	SAF67	4	6.7	1274	207.48	2.95	SF 97	4
26	284	54.00	1.65			7.5	1154	187.89	3.26	SA 97	4
30	242	45.98	1.89								
34	220	41.79	2.07			4.1	2074	222.00	1.03	S 87	6
39	190	36.20	2.40			4.6	1850	198.00	1.16	SF 87	6
44	165	31.50	2.75			5.5	1555	166.43	1.25	SA 87	6
53	139	26.40	2.88			6.1	1429	152.95	1.32	SAF87	6

S



输出转速 Output speed r/min	输出扭矩 Output torque Nm	传动比 Ratio i	使用系数 Service factor f _B	机 型 号 Type Type	极 数 Pole p	输出转速 Output speed r/min	输出扭矩 Output torque Nm	传动比 Ratio i	使用系数 Service factor f _B	机 型 号 Type Type	极 数 Pole p
1.5kW						2.2kW					
6.3	1363	222.00	1.56			3.4	4350	420	0.86	S 97R57	4
7.1	1216	198.00	1.63			3.8	3894	376	0.97	SF 97R57	4
8.4	1022	166.43	1.90	S 87	4	4.3	3387	327	1.11	SA 97R57	4
9.2	939	152.95	2.02	SF 87	4	4.9	2972	287	1.26	SAF97R57	4
10	834	135.83	2.21	SA 87	4	5.6	2610	252	1.44		
12	746	121.44	1.92	SAF87	4						
13	970	109.19	2.65			4.1	3091	230.48	1.22	S 97	6
15	582	94.77	2.60			4.5	2782	207.48	1.35	SF 97	6
						5.0	2520	187.89	1.49	SA 97	6
										SAF97	6
7.4	1160	188.89	1.03			6.2	2046	230.48	1.84		
8.4	1018	165.75	1.17			6.8	1842	207.48	2.04		
8.9	964	157.08	1.24			7.6	1668	187.89	2.25	S 97	4
10	844	137.48	1.41			8.5	1479	166.62	2.54	SF 97	4
11	760	123.86	1.57			9.4	1337	150.64	2.64	SA 97	4
13	667	108.65	1.79	S 77	4	11	1133	127.68	3.06	SAF97	4
15	589	95.88	1.87	SF 77	4	13	990	111.52	3.24		
16	564	85.00	2.00	SA 77	4	15	863	93.27	3.37		
18	522	78.78	1.80	SAF77	4	17	828	83.31	3.56		
19	517	72.22	2.01								
22	454	63.38	2.30			6.4	1971	222.00	1.08		
23	430	60.06	2.29			7.2	1758	198.00	1.13		
27	377	52.57	2.77			8.5	1477	166.43	1.32		
30	339	47.36	2.77			9.3	1358	152.95	1.39		
34	298	41.54	3.50			10	1206	135.83	1.54	S 87	4
						12	1078	121.44	1.33	SF 87	4
17	513	83.57	0.95			13	969	109.19	1.84	SA 87	4
19	466	72.39	1.05			15	841	94.77	1.80	SAF87	4
22	444	65.00	1.10			17	753	84.86	2.29		
23	410	63.00	1.19			19	733	75.63	1.94		
24	387	57.19	1.11			20	700	70.40	2.43		
26	367	54.00	1.22			21	630	67.62	2.30		
30	329	45.98	1.38	S 67	4	23	625	60.80	2.41		
34	299	41.79	1.52	SF 67	4	27	547	52.77	2.78		
39	259	36.20	1.76	SA 67	4						
44	226	31.50	2.01	SAF67	4	10	1220	137.48	0.98		
53	216	26.40	2.11			11	1100	123.86	1.09		
59	195	23.83	2.33			13	965	108.65	1.24		
67	171	20.92	2.65			15	851	95.88	1.40		
71	162	19.80	1.99			17	755	85.00	1.46		
83	138	16.86	3.30			18	816	78.78	1.24		
91	125	15.32	2.58			20	748	72.22	1.35		
106	109	13.27	2.96			22	656	63.38	1.59	S 77	4
121	95	11.55	4.25			24	622	60.06	1.58	SF 77	4
						27	544	52.57	1.92	SA 77	4
43	247	32.80	0.98			30	491	47.36	1.9	SAF77	4
46	235	30.12	1.02			34	430	41.54	2.43		
54	214	26.11	1.08			39	380	36.66	2.75		
57	200	24.40	1.12	S 57	4	44	337	32.50	3.10		
66	173	21.09	1.34	SF 57	4	51	307	27.75	3.64		
78	147	17.92	1.08	SA 57	4	55	287	25.93	3.91		
88	131	16.00	1.55	SAF57	4	62	269	22.75	3.84		
102	112	13.67	1.41			66	255	21.56	3.91		
109	105	12.80	1.52								
130	88	10.78	1.82			31	476	45.98	1.03		
						34	433	41.79	1.13		
96	119	14.52	0.87	S 47	4	39	375	36.20	1.30		
103	111	13.60	0.93	SF 47	4	45	326	31.50	1.50		
122	94	11.46	1.10	SA 47	4	54	312	26.40	1.56	S 67	4
				SAF47	4	60	282	23.83	1.73	SF 67	4
						68	248	20.97	1.97	SA 67	4
						72	234	19.80	1.38	SAF67	4
						84	200	16.86	2.25		
						93	181	15.32	1.78		
						107	157	13.27	2.05		
						123	137	11.55	2.93		

S



S

输出转速 Output speed r/min	输出扭矩 Output torque Nm	传动比 Ratio i	使用系数 Service factor f _B	机型号 Type Type	极数 Pole p	输出转速 Output speed r/min	输出扭矩 Output torque Nm	传动比 Ratio i	使用系数 Service factor f _B	机型号 Type Type	极数 Pole p
2.2kW						3kW					
89	189	16.00	1.08	S 57	4	39	511	36.20	0.96		
104	162	13.67	0.98	SF 57	4	45	445	31.50	1.10		
111	152	12.80	1.05	SA 57	4	54	426	26.40	1.15		
132	128	10.78	1.25	SAF57	4	60	385	23.83	1.27	S 67	4
3kW						68	338	20.97	1.44	SF 67	4
4.9	4053	287	0.93	S 97R57	4	72	320	19.80	1	SA 67	4
				SF 97R57	4	84	272	16.86	1.67	SAF67	4
				SA 97R57	4	93	247	15.32	1.3		
				SAF97R57	4	107	214	13.27	1.5		
6.2	2790	230.48	1.35			123	186	11.55	2.17		
6.8	2512	207.48	1.50			104	221	13.67	0.8	S 57	4
7.6	2275	187.89	1.65			111	207	12.80	0.85	SF 57	4
8.5	2017	166.62	1.86	S 97	4	132	174	10.78	0.92	SA 57	4
9.4	1824	150.64	2.06	SF 97	4					SAF57	4
11	1546	127.68	2.20	SA 97	4	4kW					
13	1350	111.52	1.90	SAF97	4	6.2	3668	230.48	1.02		
15	1129	93.27	2.20			6.9	3302	207.48	1.14		
17	1177	83.31	2.61			7.7	2991	187.89	1.26		
18	978	80.75	2.50			8.6	2652	166.62	1.42		
8.5	2015	166.43	1.06			9.6	2398	150.64	1.57	S 97	4
9.3	1852	152.95	1.02			11	2032	127.68	1.85	SF 97	4
10	1644	135.83	1.13			13	1775	111.52	1.9	SA 97	4
12	1470	121.44	0.97			15	1547	93.27	1.94	SAF97	4
13	1322	109.19	1.35			17	1485	83.31	1.98		
15	1147	94.77	1.32			18	1399	80.75	2.01		
17	1027	84.86	1.68	S 87	4	19	1285	75.32	2.09		
19	1068	75.63	1.42	SF 87	4	23	1185	63.84	2.64		
20	955	70.40	1.78	SA 87	4	26	1035	55.76	2.80		
21	859	67.62	1.69	SAF87	4	12	1933	121.44	0.98		
23	852	60.80	1.76			13	1738	109.19	1.02		
27	745	52.77	2.04			15	1508	94.77	1.00		
30	696	47.25	2.27			17	1404	84.86	1.27		
33	667	43.13	2.50			19	1351	75.63	1.08		
36	617	39.20	2.74			20	1256	70.40	1.35		
37	554	38.25	2.46			21	1129	67.62	1.28		
42	481	34.09	2.58			24	1121	60.80	1.34	S 87	4
17	1113	85.00	1.07			27	980	52.77	1.55	SF 87	4
18	1029	78.78	0.91			30	915	47.25	1.73	SA 87	4
20	1020	72.22	1.02			33	877	43.13	1.92	SAF87	4
22	895	63.38	1.16			37	812	39.20	2.08		
24	848	60.06	1.16			38	728	38.25	1.87		
27	742	52.57	1.40			42	682	34.09	2.10		
30	669	47.36	1.40			45	633	32.15	2.22		
34	587	41.54	1.78	S 77	4	49	627	29.55	2.42		
39	518	36.66	2.01	SF 77	4	55	557	26.24	2.11		
44	459	32.50	2.27	SA 77	4	61	498	23.46	3.05		
51	419	27.75	2.66	SAF77	4	24	1115	60.06	0.88		
55	392	25.93	2.87			27	976	52.57	1.07		
62	367	22.75	2.82			30	879	47.36	1.06		
66	348	21.56	2.86			35	771	41.54	1.35		
75	305	18.87	3.17			39	681	36.66	1.53		
84	274	17.00	2.44			44	604	32.50	1.73		
95	241	14.91	3.86			52	550	27.75	2.02	S 77	4
108	212	13.16	3.15			56	515	25.93	2.18	SF 77	4
122	188	11.67	4.69			63	483	22.75	2.14	SA 77	4
143	161	9.96	4.15			67	458	21.56	2.17	SAF77	4
						76	400	18.87	2.42		
						85	361	17.00	1.85		
						97	316	14.91	2.94		
						109	279	13.16	2.40		
						123	248	11.67	3.56		
						145	211	9.96	3.17		



输出转速 Output speed r/min	输出扭矩 Output torque Nm	传动比 Ratio i	使用系数 Service factor f _B	机型号 Type Type	极数 Pole p	输出转速 Output speed r/min	输出扭矩 Output torque Nm	传动比 Ratio i	使用系数 Service factor f _B	机型号 Type Type	极数 Pole p
4kW						7.5kW					
73	420	19.80	1.16	S 67	4	13	3304	111.52	1.01		
85	358	16.86	1.27	SF 67	4	16	2880	93.27	1.19		
94	325	15.32	0.99	SA 67	4	17	2764	83.31	1.07		
109	282	13.27	1.14	SAF67	4	18	2604	80.75	1.29		
125	245	11.55	1.64			19	2393	75.32	1.13		
5.5kW						23	2207	63.84	1.43	S 97	4
8.6	3647	166.62	1.03			26	1928	55.76	1.43	SF 97	4
9.6	3297	150.64	1.14			31	1612	46.64	1.95	SA 97	4
11	2794	127.68	1.35			36	1438	40.38	2.26	SAF97	4
13	2441	111.52	1.36			40	1396	36.39	2.19		
15	2127	93.27	1.60	S 97	4	45	1294	32.76	2.43		
17	2041	83.31	1.44	SF 97	4	49	1172	29.67	2.69		
18	1923	80.75	1.73	SA 97	4	55	1039	26.31	3.03		
19	1767	75.32	1.52	SAF97	4	61	940	23.79	3.25		
23	1630	63.84	1.92			72	796	20.16	3.61		
26	1424	55.76	1.93			11kW					
31	1191	46.64	2.63			31	1704	47.25	0.93		
36	1031	40.38	3.04			34	1633	43.13	1.04		
17	1931	84.86	0.93			37	1511	39.20	1.12		
19	1857	75.63	0.95			38	1355	38.25	1.01		
20	1727	70.40	0.98			43	1270	34.09	1.29		
21	1552	67.62	0.93			45	1178	32.15	1.20	S 87	4
24	1541	60.80	0.97			49	1167	29.55	1.31	SF 87	4
27	1347	52.77	1.12			56	1037	26.24	1.14	SA 87	4
30	1259	47.25	1.26			62	927	23.46	1.65	SAF87	4
33	1206	43.13	1.40	S 87	4	69	833	21.09	1.42		
37	1116	39.20	1.51	SF 87	4	80	723	18.31	2.11		
38	1001	38.25	1.36	SA 87	4	89	648	16.39	1.83		
42	938	34.09	1.74	SAF87	4	107	537	13.60	2.20		
45	870	32.15	1.62			123	467	11.83	2.53		
49	862	29.55	1.76			53	1024	27.75	1.09		
55	766	26.24	1.53			56	959	25.93	1.17		
61	685	23.46	2.21			64	899	22.75	1.15	S 77	4
68	615	21.09	1.91			68	852	21.56	1.17	SF 77	4
79	534	18.31	2.84			77	746	18.87	1.30	SA 77	4
88	478	16.39	2.46			86	672	17.00	1.00	SAF77	4
106	397	13.60	2.96			98	589	14.91	1.59		
122	345	11.83	3.41			111	520	13.16	1.29		
35	1061	41.54	0.98			125	461	11.67	1.92		
39	936	36.66	1.11			147	394	9.96	1.71		
44	830	32.50	1.25			11kW					
52	757	27.75	1.58			26	2808	55.76	0.98		
56	709	25.93	1.58	S 77	4	31	2349	46.64	1.33		
63	664	22.75	1.55	SF 77	4	36	2095	40.38	1.54		
67	629	21.56	1.58	SA 77	4	40	2034	36.39	1.49	S 97	4
76	551	18.87	1.75	SAF77	4	45	1886	32.76	1.66	SF 97	4
85	496	17.00	1.35			49	1708	29.67	1.83	SA 97	4
97	435	14.91	2.14			55	1514	26.31	2.07	SAF97	4
109	384	13.16	1.74			61	1369	23.79	2.22		
123	341	11.67	2.59			72	1160	20.16	2.46		
145	291	9.96	2.30			83	1014	17.61	2.43		
94	447	15.32	0.78	S 67	4	99	848	14.73	3.21		
109	387	13.27	0.83	SF 67	4	115	734	12.75	3.36		
125	337	11.55	1.19	SA 67	4	56	1510	26.24	0.89		
				SAF67	4	62	1350	23.46	1.12	S 87	4
						69	1214	21.09	0.97	SF 87	4
						80	1054	18.31	1.44	SA 87	4
						89	943	16.39	1.24	SAF87	4
						107	783	13.60	1.50		
						123	681	11.83	1.72		

S



输出转速 Output speed r/min	输出扭矩 Output torque Nm	传动比 Ratio i	使用系数 Service factor f _B	机 型 号 Type Type	极 数 Pole p	输出转速 Output speed r/min	输出扭矩 Output torque Nm	传动比 Ratio i	使用系数 Service factor f _B	机 型 号 Type Type	极 数 Pole p
15kW											
31	3203	46.64	0.97								
36	2856	40.38	1.13								
40	2773	36.39	1.09								
45	2571	32.76	1.21	S 97	4						
49	2329	29.67	1.34	SF 97	4						
55	2065	26.31	1.51	SA 97	4						
61	1867	23.79	1.62	SAF97	4						
72	1582	20.16	1.8								
83	1382	17.61	1.78								
99	1156	14.73	2.35								
115	1001	12.75	2.46								
89	1287	16.39	0.91	S 87	4						
107	1068	13.60	1.10	SF 87	4						
123	929	11.83	1.25	SA 87	4						
				SAF87	4						
18.5kW											
40	3499	36.39	0.87								
45	3150	32.76	0.99								
50	2853	29.67	1.09	S 97	4						
56	2530	26.31	1.23	SF 97	4						
62	2287	23.79	1.32	SA 97	4						
73	1938	20.16	1.47	SAF97	4						
83	1693	17.61	1.45								
100	1416	14.73	1.92								
115	1226	12.75	2.01								
22kW											
56	3008	26.31	1.04								
62	2720	23.79	1.11	S 97	4						
73	2305	20.16	1.24	SF 97	4						
83	2014	17.61	1.22	SA 97	4						
100	1684	14.73	1.61	SAF97	4						
115	1458	12.75	1.69								

S



Mamax Permissible torque Nm	输出转速 Output speed r/min	传动比 Ratio i	机型号 Type Type	功率 Power kW/4p	Mamax Permissible torque Nm	输出转速 Output speed r/min	传动比 Ratio i	机型号 Type Type	功率 Power kW/4p	
90	7.8	179	S 37R17 SF 37R17 SA 37R17 SAF37R17	0.18	2280	0.24	5875	S 87R57 SF 87R57 SA 87R57 SAF87R57	0.18	
	8.8	158				0.27	5187			0.25
	9.7	144				0.30	4606			
	12	118				0.36	3872			
	13	110		0.40		3475	0.37			
170	3.6	388	S 47R17 SF 47R17 SA 47R17 SAF47R17	0.18		0.48			2905	0.55
	4.1	336				0.54	2586			
	4.7	294				0.60	2335			
	5.4	257		0.25		0.68	2054			
	6.1	229				0.76	1824			
	7.0	200			0.85	1631				
	7.4	187			1.0	1332				
8.4	165	1.2	1191	0.75						
300	2.4	574	S 57R17 SF 57R17 SA 57R17 SAF57R17		0.18	1.3	1032	1.1		
	2.7	506		1.5		930				
	3.2	438		1.7		831				
	3.6	388		1.9		719				
	4.1	336		0.25	2.2	624	1.5			
	4.7	294			2.5	558				
	5.2	269			2.9	485				
	6.1	229		0.37	3.2	435				
	6.8	204			3.7	378				
	7.4	187			4.4	323				
8.4	165	0.55	5.1	281	2.2					
11	131									
520	1.3	1045	S 67R37 SF 67R37 SA 67R37 SAF67R37	0.18	4000	0.16	8608	S 97R57 SF 97R57 SA 97R57 SAF97R57	0.18	
	1.5	914				0.18	7554			
	1.7	809				0.21	6640			
	2.0	712				0.24	5780			
	2.3	615		0.25		0.28	4937			
	2.6	543				0.31	4444			
	3.0	469		0.37		0.35	4017		0.25	
	3.3	424				0.40	3453			
	3.8	365				0.45	3108			
	4.4	319		0.55		0.52	2654		0.37	
	4.9	281				0.60	2329			
5.7	246	0.67	2081							
6.3	221	0.75	1860							
7.0	198	0.75	0.88	1574	0.55					
1270	0.45		3098	S 77R37 SF 77R37 SA 77R37 SAF77R37		0.18	1.0	1394	0.75	
	0.67	2083	1.1		1223					
	0.77	1813	1.3		1070					
	0.80	1745	1.5		928					
	0.87	1600	1.7		824					
	1.0	1404	0.25		2.0	714	1.1			
	1.1	1245			2.2	626				
	1.3	1100			2.6	538				
	1.5	954	0.37		2.9	484	1.5			
	1.7	837			3.4	420				
	1.9	714	0.55		3.8	376	2.2			
	2.2	637			4.3	327				
	2.4	574			4.9	287				
2.8	499	0.75	5.7	252	3					
3.2	438		6.6	219						
3.6	389	1.1			4					
4.3	327									
4.8	289									
5.6	250									
6.4	219									

表上所配功率均有超载,按实际条件确定的转扭不得大于减速机额定转扭。

The power are all overload in the table. The decided torque according to operating condition should not more than gear units' nominal torque.

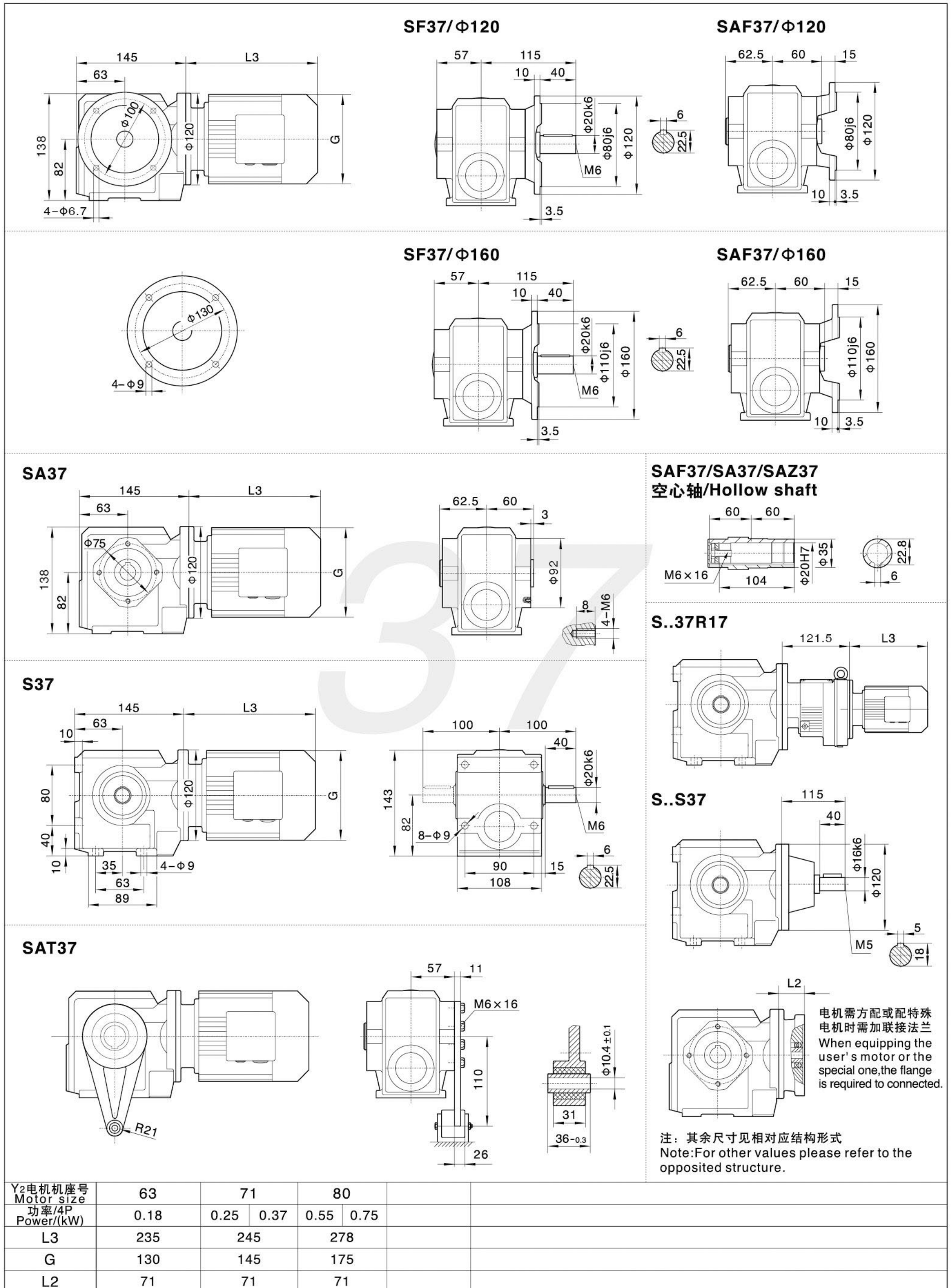

S

注:1.SA、SF、SAF、SAZ壳体为通用件,安装尺寸均可相互参照。2."S.."表示S、SA、SF、SAF、SAZ
Note:1.The housings of SA、SF、SAF、SAZ are common parts.The mounting dimensions may consult each other. 2."S.."mean S、SA、SF、SAF、SAZ

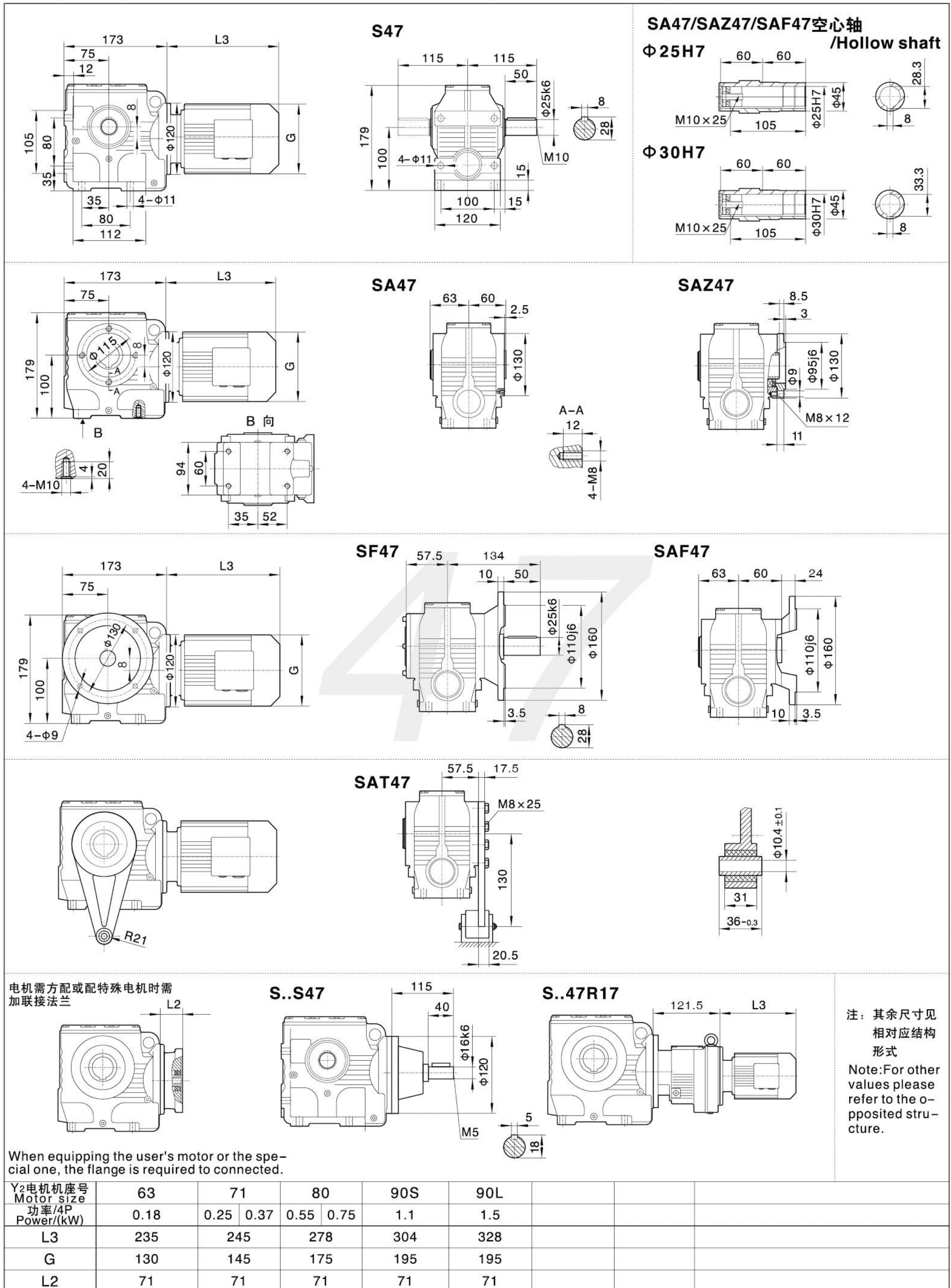

S

注:1.SA、SF、SAF、SAZ壳体为通用件,安装尺寸均可相互参照。2."S.."表示S、SA、SF、SAF、SAZ

Note:1.The housings of SA、SF、SAF、SAZ are common parts.The mounting dimensions may consult each other. 2."S.."mean S、SA、SF、SAF、SAZ



S57

SA57/SAZ57/SAF57空心轴 /Hollow shaft

Φ 30H7

Φ 35H7

SA57

SAZ57

SF57

SAF57

SAT57

电机需方配或配特殊电机时需加联接法兰

S..S57

S..57R17

注: 其余尺寸见相对应结构形式
Note: For other values please refer to the opposed structure.

When equipping the user's motor or the special one, the flange is required to connected.

Y2电机座号 Motor size	63	71	80	90S	90L	100			
功率/4P Power/(kW)	0.18	0.37	0.55 0.75	1.1	1.5	2.2 3.0			
L3	235	245	278	304	328	340			
G	130	145	175	195	195	215			
L2	71	71	71	71	71	93			

S

注:1.SA、SF、SAF、SAZ壳体为通用件,安装尺寸均可相互参照。2."S.."表示S、SA、SF、SAF、SAZ
Note:1.The housings of SA、SF、SAF、SAZ are common parts.The mounting dimensions may consult each other. 2."S.."mean S、SA、SF、SAF、SAZ

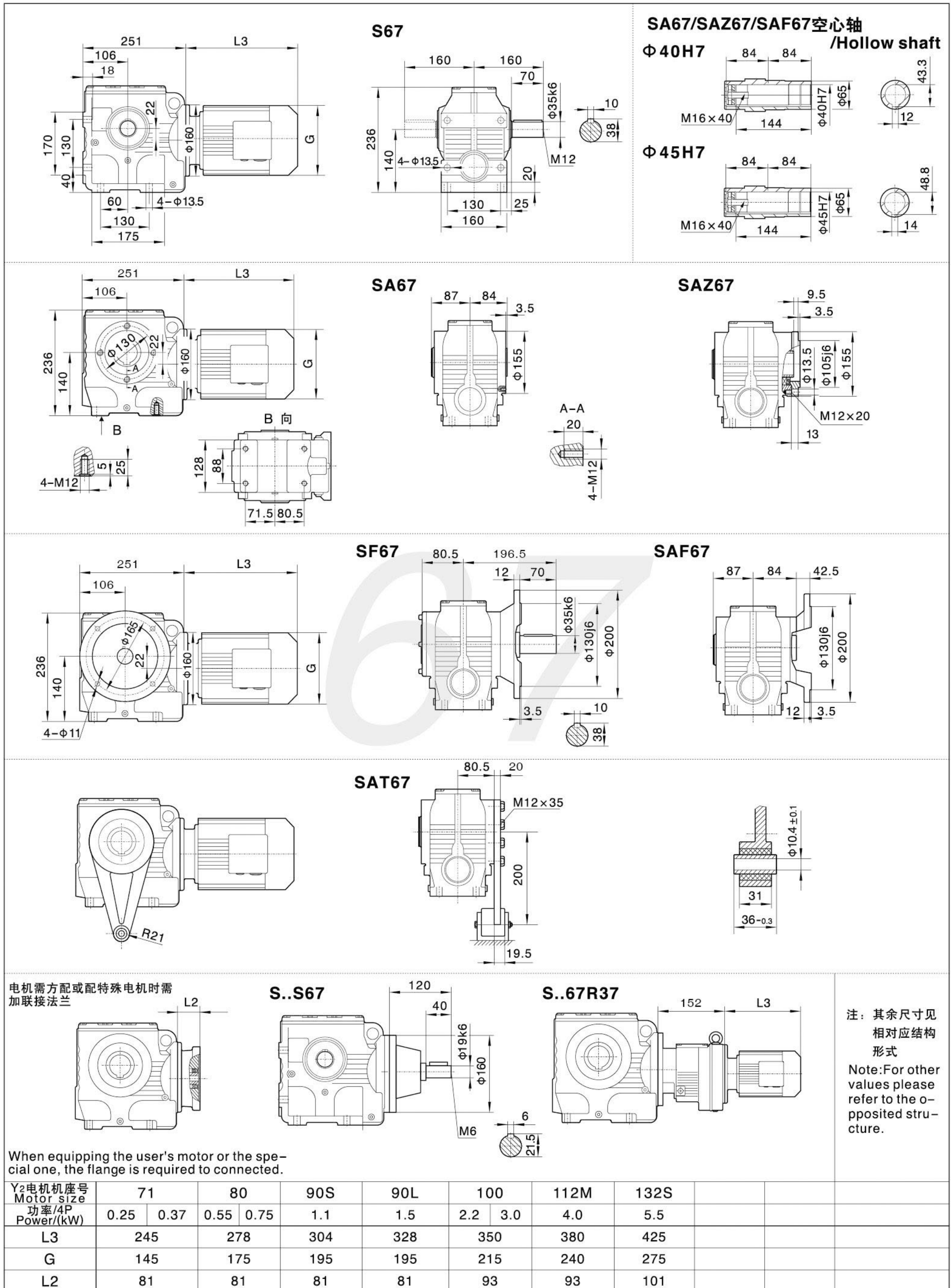

S



S77

SA77

SAZ77

SA77/SAZ77/SAF77空心轴 /Hollow shaft

φ50H7

φ60H7

SF77

SAF77

SAT77

电机需方配或配特殊电机时需加联接法兰

S..S77

S..77R37

When equipping the user's motor or the special one, the flange is required to connected.

Y2电机机座号 Motor size	80	90S	90L	100	112M	132S	132M
功率/4P Power/(kW)	0.55 0.75	1.1	1.5	2.2 3.0	4.0	5.5	7.5
L3	278	304	328	350	380	425	461
G	175	195	195	215	240	275	275
L2	81	81	81	93	93	101	101

注: 其余尺寸见相对应结构形式
Note: For other values please refer to the o-pposited stru-cture.

S

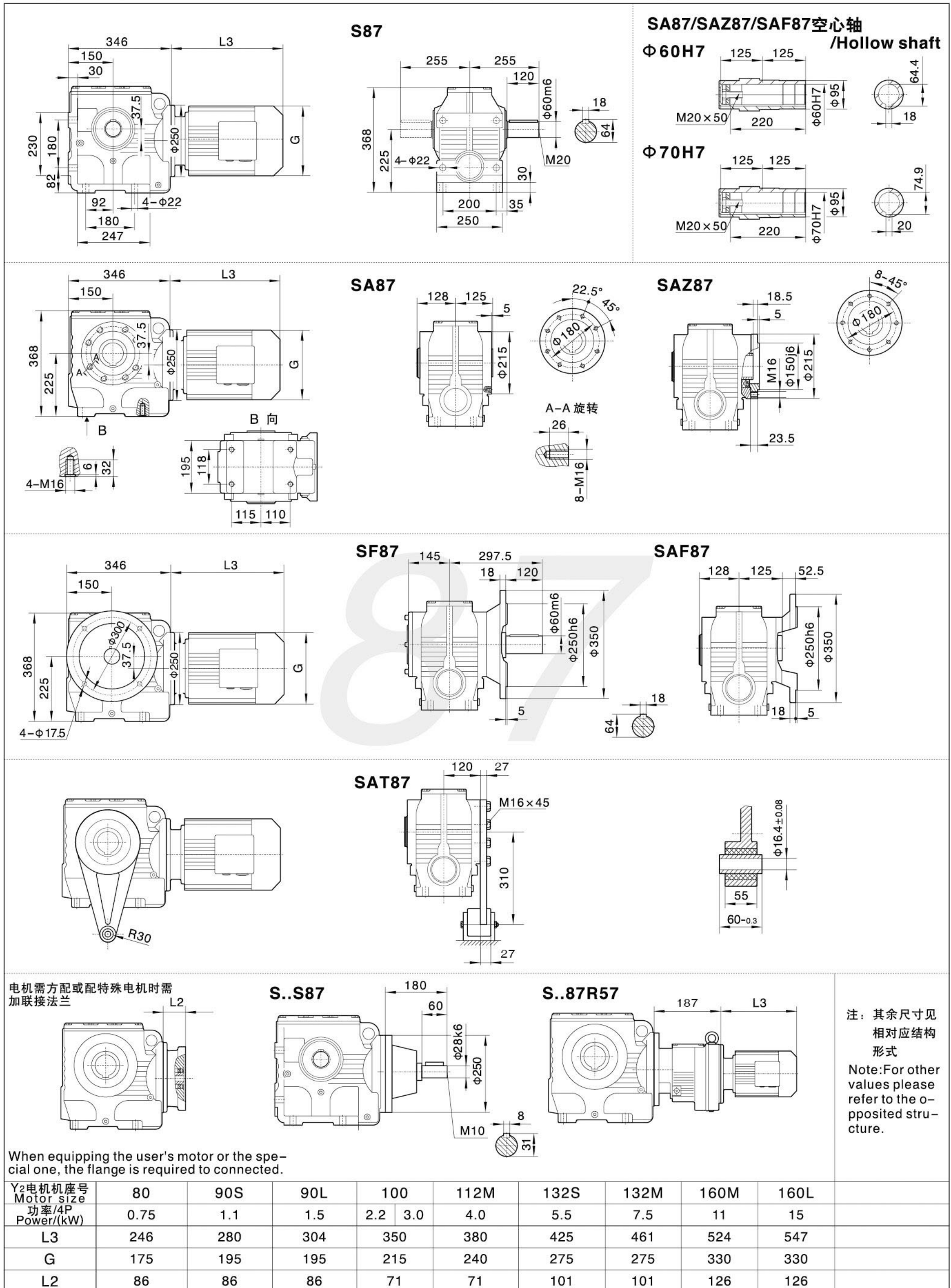

S

注：其余尺寸见
相对应结构
形式
Note:For other
values please
refer to the o-
pposited stru-
cture.

注:1.SA、SF、SAF、SAZ壳体为通用件,安装尺寸均可相互参照.2."S.."表示S、SA、SF、SAF、SAZ

Note:1.The housings of SA、SF、SAF、SAZ are common parts.The mounting dimensions may consult each other. 2."S.."mean S、SA、SF、SAF、SAZ



S97

**SA97/SAZ97/SAF97空心轴
/Hollow shaft**

Φ70H7

Φ90H7

SA97

SAZ97

SF97

SAF97

SAT97

电机需方配或配特殊电机时需加联接法兰

When equipping the user's motor or the special one, the flange is required to connected.

S..S97

S..97R57

注：其余尺寸见相对应结构形式
Note: For other values please refer to the opposed structure.

Y2电机座号 Motor size	90L	100	112M	132S	132M	160M	160L	180M	180L
功率/4P Power/(kW)	1.5	2.2 3.0	4.0	5.5	7.5	11	15	18.5	22
L3	304	315	334	425	461	524	547	555	588
G	195	215	240	275	275	330	330	380	380
L2	86	86	86	101	101	126	126	126	126