



代号标记注解
SIGN EXPLANTION

表1
(Table 1)

NMRV	带输入法兰式减速机(配合电机使用) With input flange (using with electric motor)
NRV	输入轴式减速机 With input shaft
25-30-40-50-63-75-110-130	减速机的机座规格(中心距参数) Type(centre distance)
7.5-10-15-20-25-30-40-50-60-80-100	公称传动比 Nominal ratio
Y 0.18	配普通Y系列电动机, 功率为0.18KW With electric motor in series Y, the power is 0.18KW
Z 0.18	配制动电机, 功率为0.18KW With breaking motor, the power is 0.18KW
F.....(1-2)	输出法兰及安装型式 Ouput flange and mounting position
TA	转矩臂 With torque arm
YZ	配延伸蜗杆轴 With extention worm shaft
DZ	配单向输出轴 With single output shaft
SZ	配双向输出轴 With double output shaft

标记方式
MODEL DESIGNATION

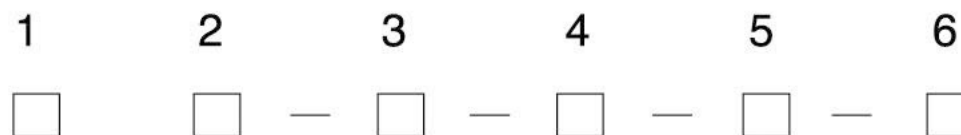

NMRV型

Model NMRV

NRV型

Model NRV

机座规格25-130

Type 25-130

公称传动比7.5-100

Nominal ratio 7.5-100

电机类型及功率(四级)Y(KW)

Electric Motor type and power Y(KW)

Z(KW)

Z(KW)

不配电机省略

Omiting without it

输入、出轴要求: YZ

Input and output shaft Code: YZ

DZ

DZ

SZ

SZ

不配省略

Omiting without it

安装用附件要求: F1

Accessory for mounting: F1

F2

F2

TA

TA

不配省略

Omiting without it



图
(Chart 1)

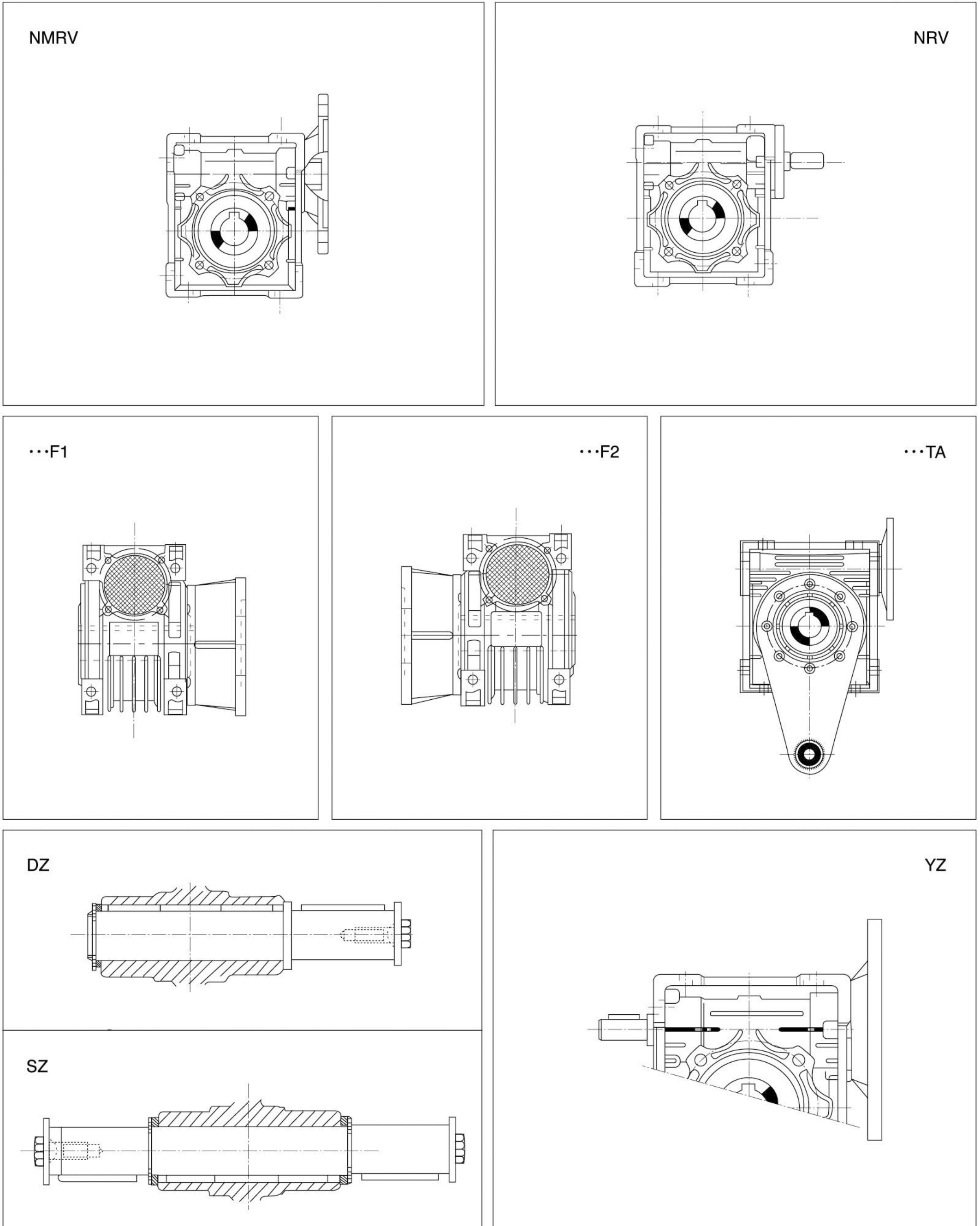

RV



标记示例:

EXAMPLE OF SIGN

1、NMRV40-30-Y0.18-F1-SZ

意为：NMRV型，机座规格40，公称传动比30，配Y系列0.18KW电机、F1输出法兰、双输出轴。

2、NRV40-30-F1

意为：NRV型，机座规格40，公称传动比30，不配电机，配输出法兰F1。

1、NMRV40-30-Y0.18-F1-SZ

Means: model: NMRV size: 40

Nominal ratio: 30

Equipped electric motor: 0.18KW in series Y

Output flange: F1

Double output shaft: SZ

2、NRV40-30-F1

Means: model: NRV size: 40

Nominal ratio: 30

Without electric motor

Output flange: F1

减速机的承载能力

THE CARRIING ABILITY OF WORM MICROREDUCER

工作系数见表2及表3

承载能力见参数表（表4、表5）

By table 2 and table 3, can find service factor of the worm microreducer.

By table 4 and table 5, can find the carrying ability of worm microreducer.

减速机的外形及安装联接尺寸

OVERALL AND MOUNTING DIMENSIONS

法兰规格、轴芯尺寸见图2、表6。

减速机的外形尺寸见图3、图4、表7。

单向/双向输出轴尺寸见图5、表8。

延伸蜗杆轴尺寸见图6、表9。

转矩臂尺寸见图7、表10。

减速机的安装型式见图8。

输出法兰安装型式见图9。

电线接线盒的安装型式见图10。

By chart 2 and table 6, can find flange types and dimensions of hollow shaft.

By chart 3, chart 4 and table 7, can find appearance demensions.

By chart 5 and table 8, can find dimensions of single/double output shaft.

By chart 6 and table 9, can find dimensions of extention shafts.

By chart 7 and table 10, can find dimensions of torque arms.

By chart 8, can find the mounting positions.

By chart 9, can find the positions of output flanges.

By chart 10, can find the positions of junction box.



使用维护要求

THE REQUIREMENT OF USING AND MAINTAIN

安装时请不要对减速机输出部件，箱体施加压力，联接时请满足机器（械）与减速机之间的同轴度与垂直度的相应要求。

减速机初始运行至400小时应重新更换润滑油，其后的换油周期约为4000小时。

箱体内应保留足够的润滑油量，并定时检查。当发现油量减少或油质变坏时应及时补足或更换润滑油。应注意保持减速机外观清洁，及时清除灰尘、污物以利于散热。

Do not make pressure on output part and box when mounting it.

It must replace lubrication oil after it runs 400 hours when first using it, after it, replace lubrication oil per running 4000 hours.

It must keep coaxial degree and vertical degree in just lever when conjoining reducer with other device.

Must keep plenty of oil lubrication in the reducer and check it often.

Must add or replace in time when ulubrication oil reduce or get bad.

It is usefull to keep reducer clean so that reducer radiates warmth more efficiently.

蜗杆减速机国内外型号对照表

Comparative table of worm microreducer model domestically

本公司	NRV25	NRV30	NRV40	NRV50	NRV63	NRV75	NRV90	NRV110	NRV130
	NMRV25	NMRV30	NMRV40	NMRV50	NMRV63	NMRV75	NMRV90	NMRV110	NMRV130
意大利	NRV25	NRV30	NRV40	NRV50	NRV63	NRV75	NRV90	NRV110	NRV130
	NMRV25	NMRV30	NMRV40	NMRV50	NMRV63	NMRV75	NMRV90	NMRV110	NMRV130
国内	WJ25	WJ30	WJ40	WJ50	WJ63	WJ75	WJ90	WJ110	WJ130
	WSJK25	WSJK30	WSJK40	WSJK50	WSJK63	WSJK75	WSJK90	WSJK110	WSJK130
	WSJZ25	WSJZ30	WSJZ40	WSJZ50	WSJZ63	WSJZ75	WSJZ90	WSJZ110	WSJZ130

根据表2及表3，可找出有关减速机的工作系数(sf)

By table 2 and 3, can find out the service factor (sf) about worm reducer.

表2
(Table 2)

每小时间断性操作次数少于10次 N° of starts per hour < 10			
加于减速机的负荷性质 Nature of load generated by driven machine	每日工作时数 Hours running per day		
	<2	2~8	8~16
带均衡负荷 Uniform	sf=0.8	sf=1	sf=1.25
带中级震荡 Moderate shock	sf=1	sf=1.25	sf=1.5
带重级震荡 Heavy shock	sf=1.25	sf=1.5	sf=1.75

RV



表3
(Table 3)

每小时间断性或连续性操作次数少于10次 N° of starts per hour >10			
加于减速机的负荷性质 Nature of load generated by driven machine	每日工作时数 Hours running per day		
	<2	2~8	8~24
带均衡负荷 Uniform	sf=1	sf=1.25	sf=1.75
带中级震荡 Moderate shock	sf=1.5	sf=1.75	sf=2
带重级震荡 Heavy shock	sf=1.75	sf=2	sf=2.25

参数表 (*工作系数=1)
Data table (sf =1)

表4
(Table 4)

I		n2	n1=1400								
			25	30	40	50	63	75	90	110	130
7.5	KW1 M2	187	0.25	0.41	0.90	1.58	2.84	4.06	6.3	10.4	16.1
			11	18	40	71	128	185	290	480	750
10	KW1 M2	140	0.21	0.32	0.69	1.23	2.19	3.25	5.11	8.57	13.5
			12	18	40	72	130	195	310	520	820
15	KW1 M2	93	0.15	0.23	0.48	0.88	1.65	2.30	4.09	6.48	10.3
			12	18	40	74	140	200	360	570	920
20	KW1 M2	70	0.12	0.18	0.37	0.68	1.22	1.88	3.10	4.83	7.76
			12	18	39	73	135	210	355	560	910
25	KW1 M2	56	-	0.18	0.30	0.54	0.98	1.47	2.43	4.12	6.49
			-	21	38	70	130	200	340	590	930
30	KW1 M2	47	0.09	0.15	0.31	0.57	1.06	1.48	2.57	3.90	6.35
			13	20	45	84	160	230	410	630	1040
40	KW1 M2	35	0.08	0.11	0.23	0.42	0.76	1.12	1.76	2.87	4.93
			13	18	41	76	145	220	360	610	1050
50	KW1 M2	28	0.06	0.09	0.18	0.34	0.60	0.89	1.38	2.35	3.83
			11	17	39	73	135	210	340	600	980
60	KW1 M2	23	0.04	0.08	0.15	0.28	0.51	0.75	1.13	1.9	3.05
			10	16	36	68	130	200	320	560	900
80	KW1 M2	18	-	0.05	0.12	0.22	0.39	0.58	0.83	1.34	2.26
			-	13	33	65	122	190	285	490	840
100	KW1 M2	14	-	-	0.09	0.16	0.34	0.48	0.67	1.07	1.70
			-	-	29	55	118	180	270	460	740



参数表(*配4级1400RPM电机)
Data table (with 4 poles, 1400rpm motor)

表5
(Table 5)

型号 Type	i	n ₂	kw ₁	M ₂	sf	型号 Type	i	n ₂	kw ₁	M ₂	sf	型号 Type	i	n ₂	kw ₁	M ₂	sf
25	7.5	186.7	0.09	4	2.8	50	7.5	186.7	0.75	33	1.7	90	7.5	186.7	4	180	1.3
	10	140	0.09	5	2.3		10	140	0.75	42	1.3		10	140	4	296	1.1
	15	93.3	0.09	7	1.6		15	93.3	0.75	58	1.0		15	93.3	4	342	0.9
	20	70	0.09	9	1.3		20	70	0.75	81	0.9		20	70	4	458	0.8
	30	46.7	0.09	12	1.0		25	56	0.55	71	1.0		25	56	3	420	0.8
	40	35	0.09	15	0.9		30	46.7	0.55	81	1.0		30	46.7	3	479	0.9
	50	28	0.06	12	0.9		40	35	0.55	101	0.8		40	35	2.20	433	0.8
	60	23.3	0.06	14	0.7		50	28	0.37	80	0.9		50	28	2.20	492	0.6
30	7.5	186.7	0.18	7	1.9	63	7.5	186.7	1.50	68	1.5	110	7.5	186.7	7.50	345	1.4
	10	140	0.18	9	1.5		10	140	1.50	88	1.2		10	140	7.50	455	1.1
	15	93.3	0.18	13	1.0		15	93.3	1.50	126	0.9		15	93.3	5.50	484	1.2
	20	70	0.18	17	0.8		20	70	1.50	166	0.8		20	70	5.50	638	0.8
	25	56	0.18	21	1.0		25	56	1.10	146	0.9		25	56	5.50	790	0.8
	30	46.7	0.18	24	0.8		30	46.7	1.10	167	1.0		30	46.7	4	647	0.9
	40	35	0.12	19	0.9		40	35	1.10	207	0.7		40	35	3	638	0.9
	50	28	0.12	23	0.8		50	28	0.55*	124	1.1		50	28	3	767	0.8
40	7.5	186.7	0.37	16	1.6	75	7.5	186.7	4	182	1.0	130	7.5	186.7	7.50	343	1.8
	10	140	0.37	27	1.3		10	140	3	180	1.1		10	140	7.50	453	1.5
	15	93.3	0.37	28	0.9		15	93.3	3	261	0.8		15	93.3	7.50	664	1.1
	20	70	0.37	39	1.0		20	70	2.20	240	0.8		20	70	7.50	864	0.8
	25	56	0.37	47	0.8		25	56	1.50	205	1.0		25	56	7.50	1074	0.8
	30	46.7	0.37	53	0.8		30	46.7	2.20	337	0.7		30	46.7	5.50	900	1.1
	40	35	0.25	44	0.9		40	35	1.10	216	1.0		40	35	5.50	1171	0.9
	50	28	0.22	47	0.8		50	28	1.10	264	0.8		50	28	5.50	1379	0.7
50	7.5	186.7	0.75	33	1.7	100	7.5	186.7	1.50	68	1.5	150	7.5	186.7	15.00	548	1.4
	10	140	0.75	42	1.3		10	140	1.50	88	1.2		10	140	15.00	755	1.1
	15	93.3	0.75	58	1.0		15	93.3	1.50	126	0.9		15	93.3	11.00	816	1.2
	20	70	0.75	81	0.9		20	70	1.50	166	0.8		20	70	11.00	1074	0.8
	25	56	0.55	71	1.0		25	56	1.10	146	0.9		25	56	11.00	1379	0.8
	30	46.7	0.55	81	1.0		30	46.7	1.10	167	1.0		30	46.7	8.00	1171	0.9
	40	35	0.55	101	0.8		40	35	1.10	207	0.7		40	35	8.00	1585	0.7
	50	28	0.37	80	0.9		50	28	0.55*	124	1.1		50	28	8.00	2000	0.7
60	7.5	186.7	1.50	68	1.5	150	7.5	186.7	15.00	548	1.4	200	7.5	186.7	30.00	816	1.4
	10	140	1.50	88	1.2		10	140	15.00	755	1.1		10	140	30.00	1117	1.1
	15	93.3	1.50	126	0.9		15	93.3	15.00	1074	0.9		15	93.3	22.00	1270	1.2
	20	70	1.50	166	0.8		20	70	15.00	1431	0.8		20	70	22.00	1685	0.8
	25	56	1.10	146	0.9		25	56	11.00	1270	0.9		25	56	22.00	2100	0.8
	30	46.7	1.10	167	1.0		30	46.7	11.00	1896	1.0		30	46.7	16.00	2515	0.9
	40	35	1.10	207	0.7		40	35	1.10	2521	0.7		40	35	16.00	2930	0.7
	50	28	0.55*	124	1.1		50	28	0.55*	3146	1.1		50	28	12.00	3345	0.7

注:	单位	Note	Unit	单位	Unit
n ₁ = 输入速度	rpm	n ₁ = Input speed	rpm	M ₂ = 输出扭矩	Nm
n ₂ = 输出速度	rpm	n ₂ = Output speed	rpm	sf = 工作系数	Nm
				sf = Service factor	





法兰安装规格 轴芯尺寸—D

The type of flange and Hollow input shaft diameter D

表6 (Table 6)

型号 Type	安装规格			公称传动比 i/Nominal ratio											
	法兰型号 Flange type	N	M	P	7.5	10	15	20	25	30	40	50	60	80	100
					D										
25	56B14	50	65	80	9	9	9	9	-	9	9	9	9	-	-
30	63B5	95	115	140	11	11	11	11	11	11	11	11	-	-	-
	63B14	60	75	90	11	11	11	11	11	11	11	11	-	-	-
40	56B14	50	65	80	9	9	9	9	9	9	9	9	9	9	-
	71B5	110	130	160	14	14	14	14	14	14	14	14	-	-	-
50	63B5	95	115	140	11	11	11	11	11	11	11	11	11	11	11
	80B5	130	165	200	19	19	19	19	19	19	-	-	-	-	-
63	71B5	110	130	160	14	14	14	14	14	14	14	14	14	14	-
	63B5	95	115	140	-	-	-	-	-	-	11	11	11	11	11
75	90B35	130	165	200	24	24	24	24	24	24	-	-	-	-	-
	80B5	130	165	200	19	19	19	19	19	19	19	19	19	19	19
	71B5	110	130	160	-	-	-	-	-	-	14	14	14	14	14
90	100/112B35	180	215	250	28	28	28	28	-	28	-	-	-	-	-
	90B35	130	165	200	24	24	24	24	24	24	24	24	24	24	24
	80B5	130	165	200	-	-	-	-	-	-	19	19	19	19	19
110	100/112B35	180	215	250	28	28	28	28	28	28	28	28	28	28	28
	132B35	230	265	300	38	38	38	38	38	-	-	-	-	-	-
	90B35	130	165	200	-	-	-	-	24	24	24	24	24	24	24
130	100/112B35	180	215	250	-	-	-	-	28	28	28	28	28	28	28
	132B35	230	265	300	38	38	38	38	38	38	38	38	-	-	-
	90B35	130	165	200	-	-	-	-	24	24	24	24	24	24	24

图2 (Chart 2)



图3 (Chart 3)



NMRV 25

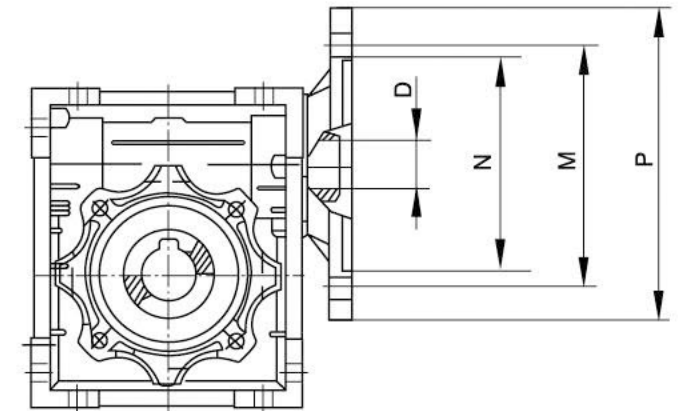
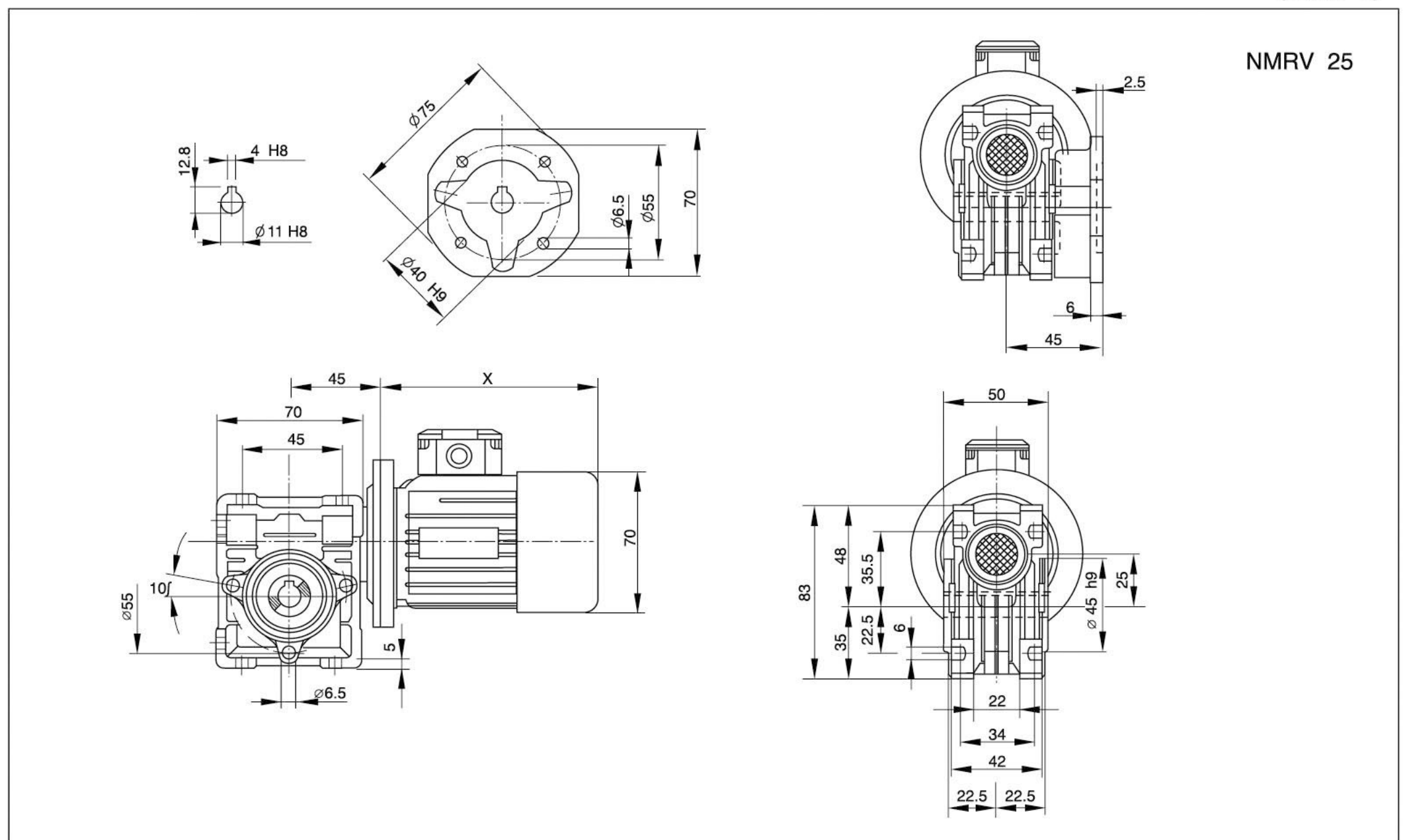

图4 (Chart 4)



表7 (Table 7)

型号 Type	尺寸 (Dimensions)																		
	A	C	D(H7)	E	F	G	H	I	L	M	N(h8)	O	P	Q	R	S	T	V	K
30	54	80	14	97	32	55	40	30	56	65	55	6.5	75	44	57	5.5	20	27	44
40	70	101	18	121.5	43	70	50	40	71	75	60	6.5	87	55	71.5	6.5	23	35	60
50	80	121.5	25	145	49	80	60	50	85	85	70	8.5	100	64	84	7	30	40	70
63	100	147.5	25	174	67	95	72	63	103	95	80	8.5	110	80	102	8	40	50	85
75	120	174	28	205	72	112.5	86	75	113	115	95	11	140	93	119	10	50	60	90
90	140	208	35	238	72	130	103	90	130	130	110	13	160	102	135	11	50	70	100
110	170	252.5	42	294		160	127.5	110	142	165	130	14	200	125	167.5	15	60	85	115
130	200	292.5	45	335	79	180	147.5	130	155	215	180	16	250	140	187.5	15	80	100	120

型号 Type	尺寸 (Dimensions)																		
	G1	G2	N1	KA	KB	KC	KE	α	KM	KN(H8)	KO	KP	KQ	d(j6)	b	t1	X	Y	
30	63	51	29	54.5	6	4	M6 X 11(n4)	0°	68	50	6.5(4/90°)	80	70	9	5	16.3	for electric motor See overall dimensions for electric motor 一览表	见电动机外形尺寸一览表	
40	78	60	36.5	67	7	4	M6 X 8(n4)	45°	87	60	9(4/90°)	110	95	11	6	20.8			
50	92	74	43.5	90	9	5	M8 X 10(n4)	45°	90	70	11(4/90°)	125	110	14	8	28.3			
63	112	90	53	82	10	6	M8 X 14(n8)	45°	150	115	11(4/90°)	180	142	19	8	28.3			
75	120	105	57	111	13	6	M8 X 14(n8)	45°	165	130	14(4/90°)	200	170	24	8	31.3			
90	140	125	67	111	13	6	M10 X 11(n8)	45°	175	152	14(4/90°)	210	200	24	10	38.3			
110	155	142	74	139	15	6	M10 X 18(n8)	45°	220	170	14(8/90°)	270	250	28	12	45.3			
130	170	162	81	151.5	15	6	M12 X 20(n8)	45°	225	180	16(8/90°)	320	290	30	14	48.8			

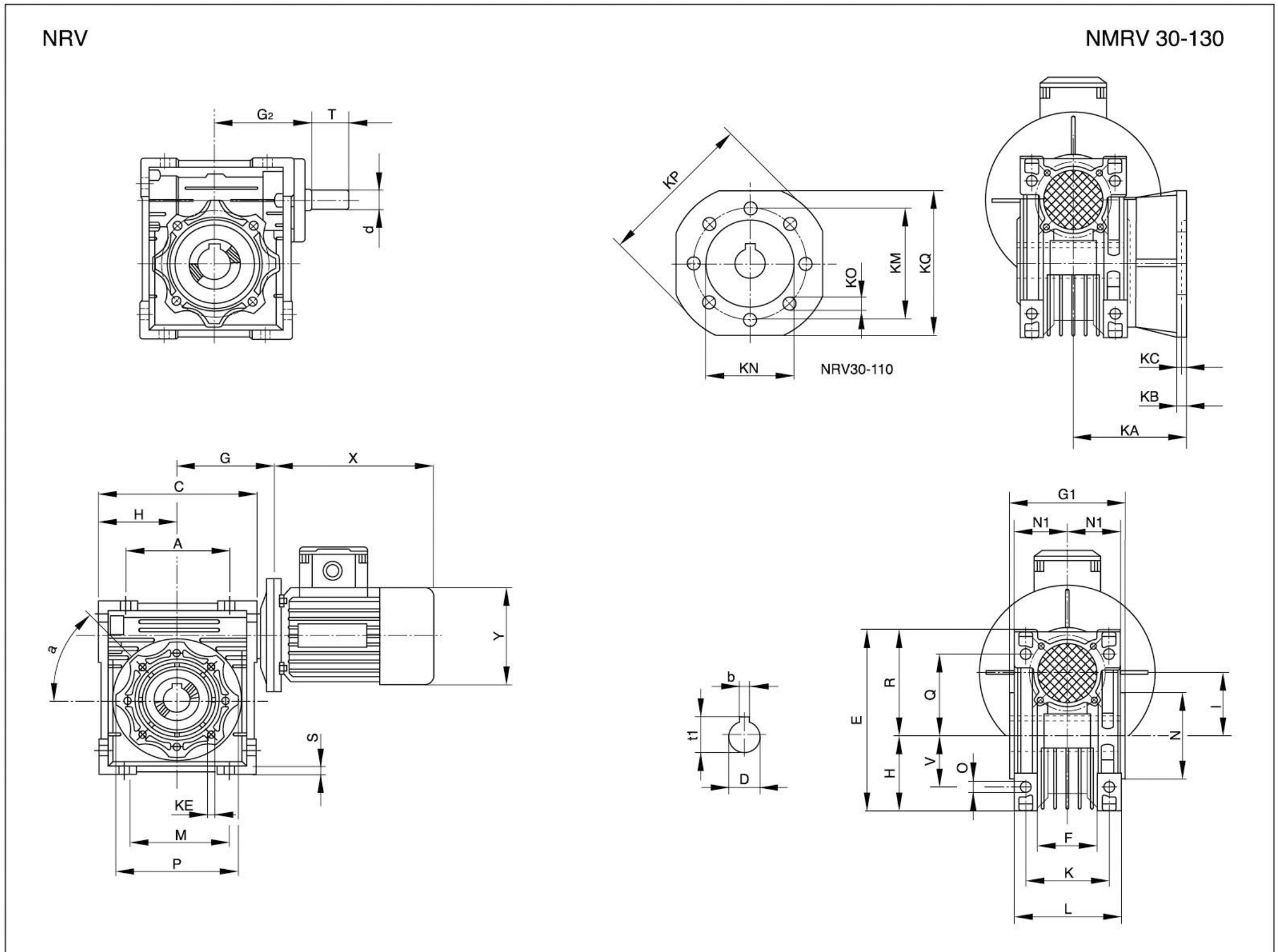

电动机外形尺寸一览表

Overall dimensions for electric motor

机座号	56		63		71		80		90		100		112		132	
功率(KW)	0.06	0.09	0.12	0.18	0.25	0.37	0.55	0.75	1.1	1.5	2.2	3	4	5.5	7.5	
X	150		207		225		255		260	285	320		340	395	435	
Y	120		130		145		165		171	171	201		226	266	266	

单向/双向输出轴尺寸

Dimensions of single (double) output shaft

图5 (Chart 5)

表8 (Tale 8)

型号 Type	D(h6)	B	B1	L	L1	f	b	t
25	11	23	25.5	81	101	-	4	12.5
30	14	30	32.5	102	128	M6	5	16
40	18	40	43	128	164	M6	6	20.5
50	25	50	53.5	153	199	M10	8	28
63	25	50	53.5	173	219	M10	8	28
75	28	60	63.5	192	247	M10	8	31
90	35	80	84	234	308	M12	10	38
110	42	80	84.5	249	324	M16	12	45
130	45	80	85	265	340	M16	14	48.5

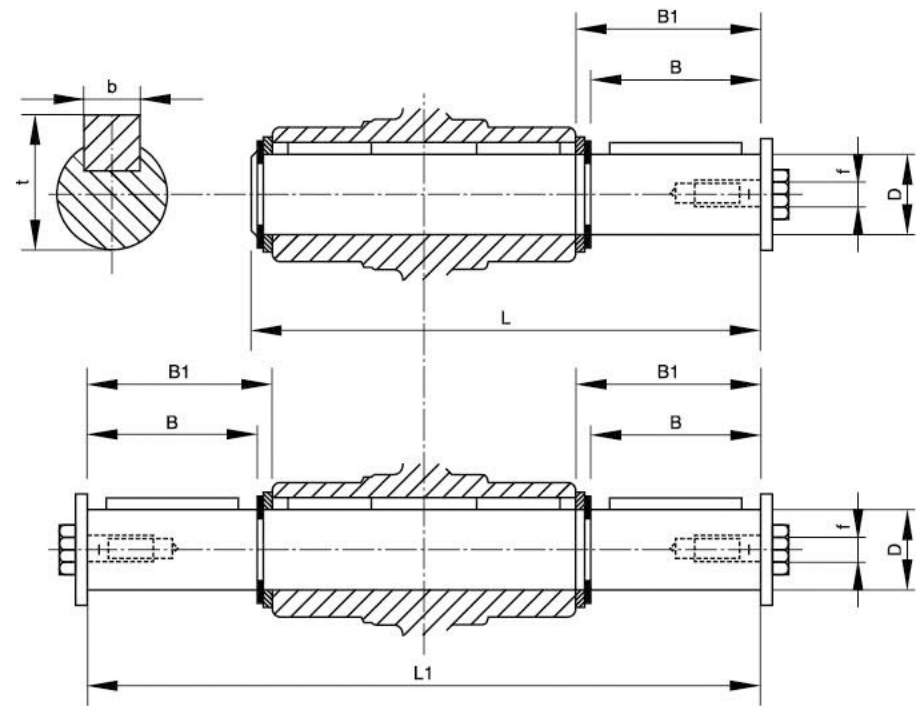

延伸蜗杆轴尺寸(轴速度与电机速度相同)

Dimensions of extension worm shafts (Speed is as same as electric motor)

表9 (Tale 9)

图6 (Chart 6)

型号 Type	B	d(j6)	T	b	t
30	45	9	20	3	10.5
40	53	11	23	4	12.5
50	64	14	30	5	16
63	75	19	40	6	21.5
75	90	24	50	8	27
90	108	24	50	8	27
110	135	28	60	8	31
130	155	30	80	8	33

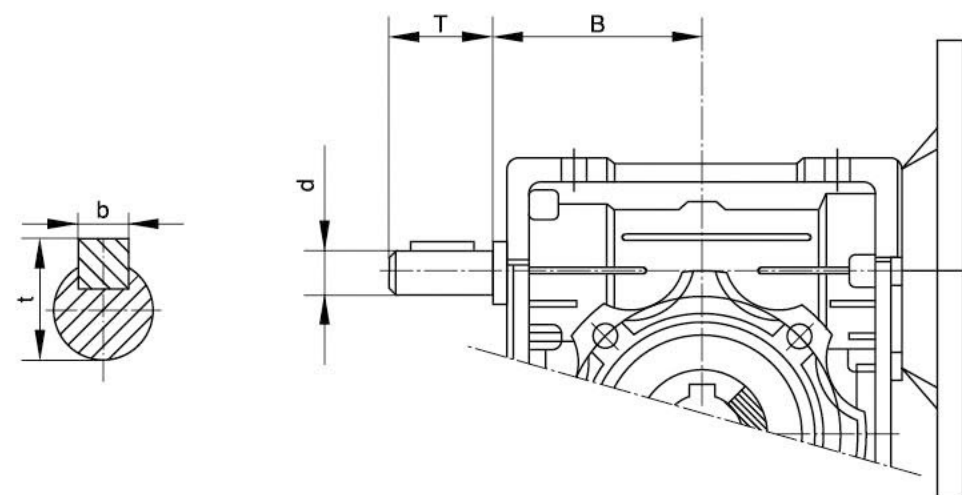

转矩臂尺寸

Dimensions of torque arms

表10 (Tale 10)

图7 (Chart 7)

型号 Type	A	B	C	D	E	F	G	H	I
25	70	33	118	45	55	7	14	8	6
30	85	38	138	55	65	7	14	8	6
40	100	44	162	60	75	7	14	10	12
50	100	50	168	70	85	9	14	10	12
63	150	55	223	80	95	9	14	10	12
75	200	70	300	95	115	9	25	20	20
90	200	80	310	110	130	11	25	20	20
110	250	100	385	130	165	11	30	25	25
130	250	125	410	180	215	14	30	25	25

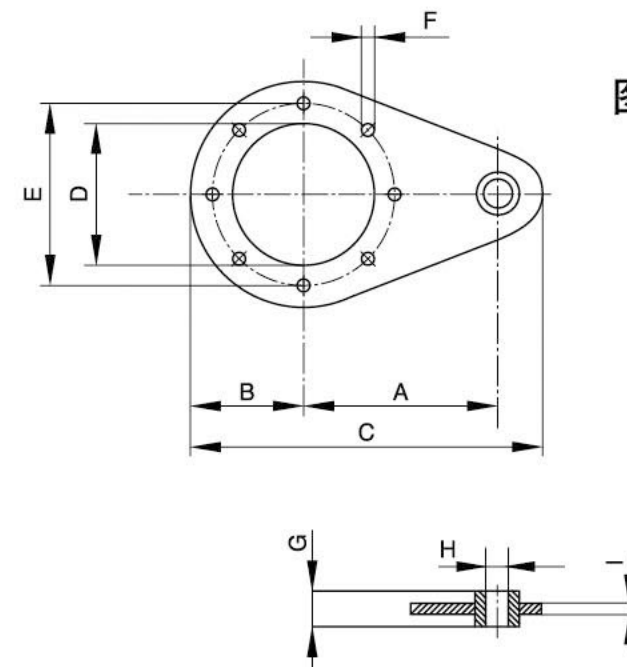



安装型式
Mounting positions

图8
Chart 8

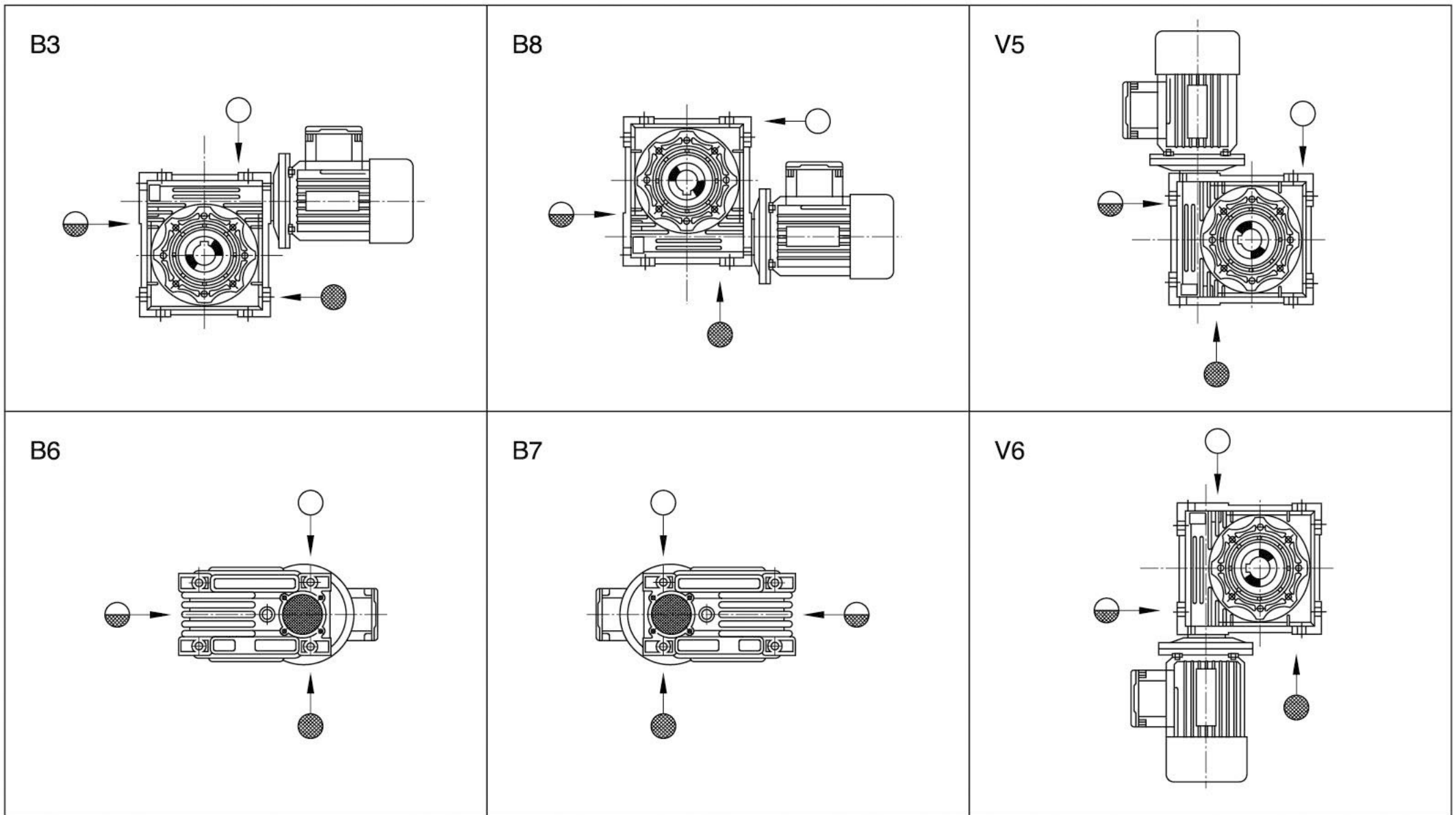

○加油孔及空气孔 ◐视油镜 ●排油栓

输出法兰“F”安装型式
Positions of output flange “F”

图9
Chart 9

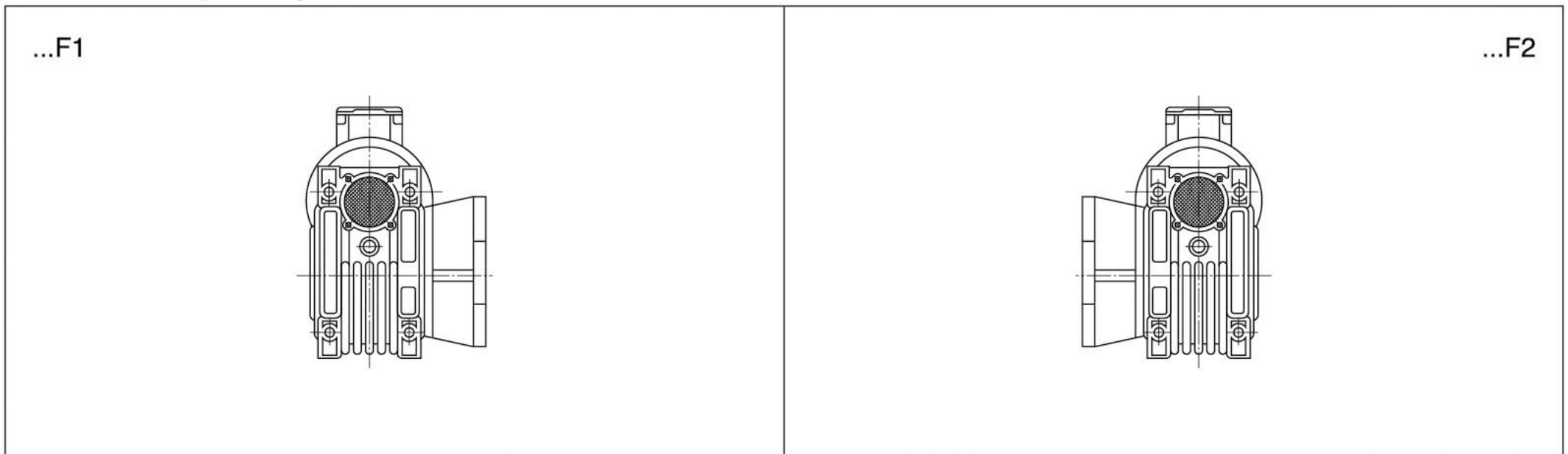

电线接线盒安装型式
Mounting positions of junction box

图10
Chart 10

